

# NEXUS

NEW TIMES MAGAZINE

Volume 9, Number 2 FEBRUARY – MARCH 2002

PO Box 30, Mapleton Qld 4560, Australia

Website: [www.nexusmagazine.com](http://www.nexusmagazine.com)

## CONTENTS

- LETTERS TO THE EDITOR.....4**
- GLOBAL NEWS.....6**  
*News you may have missed, including protests over the FDA's stance on toxic chemicals formed in irradiated food, moves to ban all space-based weapons, and plans to give unprecedented powers to Australia's domestic spying agency, ASIO.*
- THE HEALTH BENEFITS OF COCONUTS—Part 1.....13**  
*By Mary Enig, PhD. The saturated fatty acids and derivative compounds in coconut oil have powerful antimicrobial and functional properties that can help restore and support good health and assist sufferers even of AIDS, cancer and diabetes.*
- PROJECT HAMMER—Part 2.....21**  
*By David G. Guyatt. Off-ledger trading programs have been used by a cabal of international bankers and intelligence operatives to manipulate the gold price and channel funds into black-budget projects.*
- THE BIBLE FRAUD—Part 2.....27**  
*By Tony Bushby. The Church fathers had a vested interest in suppressing the belief that Jesus had a twin brother and that they were the sons of Tiberius before he became Emperor of Rome.*
- THE CANADIAN HOLOCAUST.....35**  
*By Rev. Kevin D. Annett. Church and government authorities, through the Canadian residential schools system, implemented a policy of genocide against the native people, but the perpetrators are still to be brought to justice for their crimes.*
- SUPER-MICROSCOPES & MORPHOGENESIS.....43**  
*By Greg Fredericks, ND. Many super-microscopes that helped revolutionise our understanding of biology in the 20th century were suppressed by the medical mafia and their inventors were persecuted.*
- SCIENCE NEWS.....49**  
*Allen Caggiano spent years developing a high-efficiency fuel implosion system before he was imprisoned on false charges, presumably because his invention posed a threat to vested interests.*
- VOLCANIC ACTIVITY & NUCLEAR TESTS.....53**  
*By Captain Bruce Cathie (Retired). Volcanic eruptions and nuclear detonations can be triggered as a function of the harmonic geometric relationship between the Earth and Sun at any given time.*
- TOWARDS FULL DISCLOSURE ON UFOs.....61**  
*By Theresa de Veto for Surfing The Apocalypse. Retired US Army/DIA analyst John Maynard had access to highly classified files which confirm the existence of UFOs and alien beings, and now urges the government and military to come clean.*
- THE TWILIGHT ZONE.....67**  
*This issue, we feature the Russian artist/mystic Nicholas Roerich's connection with the mysterious Chintamani Stone and his search for the fabled lost kingdom of Agharta and city of Shambhala.*
- REVIEWS—Books.....71**  
*"K2: Quest of the Gods" by Ralph Ellis  
"The Orion Prophecy" by Patrick Geryl & Gino Ratinckx  
"Princess Diana: The Hidden Evidence" by Jon King & J. Beveridge  
"Altai-Himalaya: A Travel Diary" by Nicholas Roerich  
"The Healing Miracles of Coconut Oil" by Bruce Fife, ND  
"You Are Being Lied To" edited by Russ Kick  
"Cancer: Cause, Cure and Cover-up" by Ron Gdanski  
"The A.T. Factor: Piece for a Jigsaw Part III" by Leonard G. Cramp  
"The World's Sixteen Crucified Saviors" by Kersey Graves  
"The Atlantis Secret" by Alan F. Alford  
"From the Motherland to the Mothership" by Shurlene B. Wallace  
"Crop Circles, Gods and Their Secrets" by Robert J. Boerman  
"Tempest & Exodus" by Ralph Ellis  
"New Zealand's Hidden Past" by Ross Wiseman*
- REVIEWS—CD-ROMs.....78**  
*"The Encyclopedia of Extraterrestrial Encounters" ed. by R.D. Story  
"Cosmic Artist: Crop Circle Photographs" by Colin Andrews*
- REVIEWS—Music.....79**  
*"Realise" by Karsh Kale  
"People's Colony No. 1" by Temple of Sound & R.-M. Qawwali  
"Euphoria" by Ian Cameron Smith  
"Through Windows & Walls" by Peter Kater & R. Carlos Nakai  
"African Odyssey" by various artists*
- NEXUS BOOKS, VIDEOS, ADS, SUBS.....87-96**

# NEXUS MAGAZINE

Volume 9, Number 2

FEBRUARY – MARCH 2002

PUBLISHED BY

NEXUS Magazine Pty Ltd, ABN 80 003 611 434

EDITOR

Duncan M. Roads

CO-EDITOR

Catherine Simons

ASSISTANT EDITOR/SUB-EDITOR

Ruth Parnell

EDITORS' ASSISTANT

Richard Giles

OFFICE ADMINISTRATOR

Jenny Hawke

CONTRIBUTORS THIS ISSUE

Mary G. Enig, PhD; David G. Guyatt;  
Tony Bushby; Rev. Kevin D. Annett, MA, MDiv;  
Greg Fredericks, ND, NMD; Allen Caggiano;  
Captain Bruce L. Cathie (Retired);  
Theresa de Veto/Surfing The Apocalypse

CARTOONS

Phil Somerville

COVER GRAPHIC

John Cook, jscook@ozemail.com.au

PRINTING

APN, Queensland, Australia

AUSTRALIAN DISTRIBUTION

Newsagents Direct Distribution

HEAD OFFICE – All Correspondence

PO Box 30, Mapleton, Qld 4560, Australia

Tel: (07) 5442 9280; Fax: (07) 5442 9381

Email: [editor@nexusmagazine.com](mailto:editor@nexusmagazine.com)

Website: [www.nexusmagazine.com](http://www.nexusmagazine.com)

NEW ZEALAND OFFICE

RD 2, Kaeo, Northland

Tel: +64 (0)9 405 1963; Fax: +64 (0)9 405 1964

Email: [nexusnz@xtra.co.nz](mailto:nexusnz@xtra.co.nz)

USA OFFICE - 2940 E. Colfax, #131,

Denver CO 80206

Tel: 303 321 5006; Fax: 720 941 9352

Email: [nexususa@earthlink.net](mailto:nexususa@earthlink.net)

UK OFFICE - 55 Queens Rd, East Grinstead, West

Sussex, RH19 1BG. Tel: +44 (0)1342 322854;

Fax: +44 (0)1342 324574

Email: [nexus@ukoffice.u-net.com](mailto:nexus@ukoffice.u-net.com)

EUROPE OFFICE - PO Box 372, 8250 AJ Dronen,

The Netherlands. Tel: +31 (0)321 380558;

Fax: +31 (0)321 318892

STATEMENT OF PURPOSE

NEXUS recognises that humanity is undergoing a massive transformation. With this in mind, NEXUS seeks to provide 'hard-to-get' information so as to assist people through these changes. NEXUS is not linked to any religious, philosophical or political ideology or organisation.

PERMISSION-TO-REPRODUCE POLICY

While reproduction and dissemination of the information in NEXUS is actively encouraged, anyone caught making a buck out of it, without our express permission, will be in trouble when we catch them!

## Editorial

Hello again, and welcome to the pages of NEXUS Magazine. First up, I would like to thank all of you who take the time to fill in the NEXUS Visitor's Book at our homepage ([www.nexusmagazine.com](http://www.nexusmagazine.com)). I start every day by reading each and every entry, and your many positive and constructive comments are most appreciated.

I would like to extend a warm invitation to readers to attend our upcoming NEXUS Conference on May 25-26. It is in Sydney, runs for the weekend and a few evenings afterwards, and will great fun as usual. We still have plenty of seats available. See the advertisement on page 3 of this issue for more details, or visit our website.

This issue opens with a declaration of war on the myth that coconuts and coconut oil are bad for your health and, even worse, fattening. In fact, as you will read, coconuts contain many antiparasitic and antibacterial properties and, if anything, help you *lose* weight. Given that in past issues we have put the boot into modern dairy milk and soy milk, could it be that coconut milk is a suitable replacement on our breakfast cereal/muesli and in tea and coffee? We await your feedback.

"Project Hammer" concludes in this issue. I hope readers appreciate the bean-spilling going on in this article. Readers who participate in the many investment schemes on offer these days may want to read this article.

Our series extracted from *The Bible Fraud* is generating letters aplenty. As to be expected, most response has come from Christians who consider it heretical even to question the Bible's authenticity. But we are also getting some informative and constructive letters which we hope to publish next edition. This issue focuses on the story of Jesus and his identical twin brother, Judas Thomas, and the identity of their Earthly father.

Please read the article on the Canadian Genocide. This is really gut-wrenching stuff, but I believe this ongoing tragedy must be exposed, stopped and investigated. Unfortunately, as you will read, this is not likely to occur unless it is reported on. It is doubtful that the Canadian media will do much, given the collusion between Church, government, medical and military interests in keeping it all quiet.

Long-term readers may remember various articles in NEXUS which, in essence, challenge the "germ theory" of disease. Here we have an article on super-microscopes and the scientists who developed them and discovered that the blood is teeming with activity. It is proposed that the blood contains many tiny micro-organisms which can change/mutate when the conditions in the blood (e.g., the pH) alter.

People interested in the harmonics of the Earth and its resultant grid system should get hours of reading out of Bruce Cathie's article. Bruce shows an harmonic mathematical relationship between nuclear test detonations, volcanic eruptions, Earth grids and the position of the Sun.

The UFO Disclosure Project is still going strong. Although you do not hear about it in the mainstream, this important project is attracting groundswell support and interest. This issue sees yet another of The Disclosure Project's witnesses step forth and speak out. Thanks to Theresa de Veto from Surfing The Apocalypse for granting permission to reprint her interview with John Maynard.

The intriguing Nicholas Roerich—Russian mystic, painter, writer and explorer—appears at last in our pages, in reference to the mysterious Chintamani Stone and the legendary city of Shambhala. I'm sure you will find this most interesting.

Finally, be sure to read Science News this issue. It contains the story of one Allen Caggiano, a brave inventor who dared to develop a carburettor of high efficiency. His experiences reflect what happens to many when vested oil/auto industry interests are threatened. However in Allen's case, he continues to expose and invent. He is giving away, for free, all the details on how his fuel implosion system works and how to make it yourself. Be sure to visit his website while you still can.

Also on a technical note, this issue represents a milestone of sorts. It is the first issue where we are having to prepare the magazine in an entirely digital format. From now on, no more cutting, pasting and glueing; it is all electronic from file to film. This means that NEXUS will soon be available in colour as PDF files for emailing.

Till then...

Duncan

## WARRANTY AND INDEMNITY

Advertisers upon and by lodging material with the Publisher for publication or authorising or approving of the publication of any material INDEMNIFY the Publisher and its servants and agents against all liability claims or proceedings whatsoever arising from the publication and without limiting the generality of the foregoing to indemnify each of them in relation to defamation, slander of title, breach of copyright, infringement of trademarks or names of publication titles, unfair competition or trade practices, royalties or violation of rights or privacy AND WARRANT that the material complies with all relevant laws and regulations and that its publication will not give rise to any rights against or liabilities in the Publisher, its servants or agents and in particular that nothing therein is capable of being misleading or deceptive or otherwise in breach of the Part V of the Trade Practices Act 1974. All expressions of opinion are published on the basis that they are not to be regarded as expressing the opinion of the Publisher or its servants or agents. Editorial advice is not specific and readers are advised to seek professional help for individual problems.

© NEXUS New Times 2001–2002



# Letters to the Editor ...

## Australia: Humanity's Cradle?

I just wanted to know what my fellow NEXUS readers think in relation to this one theory I have.

Australia is one of the oldest continents in the world, with the world's oldest living surviving culture of people: the Australian indigenous people, who have paintings that date as far back as 40,000 years. I put the following questions to readers of NEXUS and also members of the scientific community.

Firstly: why is there still a theory in use today that Australian Aboriginal people came from Asia, even though no archaeological evidence exists in other parts of Asia that would corroborate this theory?

And secondly: is it possible that because Australian Aboriginal culture is the oldest surviving culture on Earth—and coupled with the fact that Australia is now populated with every race of people from all corners of the globe and has every climate on Earth in its boundaries (i.e., tropical and subtropical in the north of Australia, snow in the southeast corner of the continent, Mediterranean and subterranean in South Australia and Western Australia and desert in 90 per cent of the country), plus the fact that the land is under the heavenly body, the Southern Cross—could Australia in theological and philosophical terms be playing a major part in the enlightenment and betterment of mankind at the dawn of the Age of Aquarius?

By writing the above, I do not wish to offend and/or insult other cultures and people of the world but just want an opinion on this theory, however far-fetched. If you would like to respond to this, emails can be sent to: blackstareagle@hotmail.com. Thank you.

Ben Rankins, Australia

## Frontier Psychiatry Warning

Dear Duncan: We read with great interest the article, "A Nutritional Approach to Treating ADHD", in the Oct–Nov 2001 issue [8/06] of your magazine. The subject matter is something that we have completed quite a deal of research on. There is an equally disturbing matter which we would like to draw to your attention.

Are you familiar with projects EPPIC, PACE and NEPP\*—the

recruitment of young people by social workers, school counsellors and the like for administering of neuroleptic drugs and the overall abuse of mentally ill people by the psychiatric profession? (\* EPPIC: Early Psychosis Prevention and Intervention Centre; PACE: Personal Assistance and Crisis Evaluation; NEPP: National Early Psychosis Project)

Unsuspecting, emotionally disturbed young people are deemed mentally ill and they are treated with psychiatric drugs instead of being given counselling and rehabilitative treatment. They are locked in mental institutions and, without consent, exposed to chemical lobotomy or ECG as well as denied other basic human rights. The general public is not aware of these experiments.

One has to wonder about the high rate of suicide amongst our youth. Shame, shame, shame!

L. Young, Australia, lyoung@terrigal.net.au

## Bush Family Supported Hitler

Dear Duncan and NEXUS staff: Hi; hope you are all well and happy. I found this amazing info at Mr Jon Rappoport's fantastic site, [nomorefakenews.com](http://nomorefakenews.com), and thought it would surely be of interest to NEXUS readers. It is a piece by Carla Binion from *Online Journal* of December 21, 2000, and states that:

"In [a] Simpson book, *The Splendid Blonde Beast*, the author wrote about George H. W. Bush's father, Prescott, and his maternal grandfather, George Herbert Walker. Both Bert Walker and Prescott Bush were powerful financial supporters of Adolf Hitler.

"Walker was president of Union Banking Corporation, a firm that traded with Germany and helped German industrialists consolidate Hitler's political power. Simpson says Union Banking became a Nazi money-laundering machine.

"Walker helped take over North American operations of Hamburg–Amerika Line, a shipping line and cover for I. G. Farben's Nazi espionage unit in the US. Hamburg–Amerika smuggled in German agents and brought in money for bribing American politicians to support Hitler. A 1934 congressional investigation showed

Hamburg–Amerika subsidized Nazi propaganda efforts in the US.

"George H. W. Bush's father, Prescott, was a board member of Union Banking. The US government investigated both Bert Walker and Prescott Bush, and under the Trading with the Enemy Act seized all shares of Union Banking, including shares held by Prescott Bush. The government held that 'huge sections of Prescott Bush's empire had been operated on behalf of Nazi Germany and had greatly assisted the German war effort'."

I always suspected those MFs to be Nazis, but to have it laid out like that so clearly is really creepy. Why have we heard nothing of this in the media? Ha! What a silly question. Keep up the struggle!

Love,

Kathryn (You'll never take me alive!) McCloghry, Australia, [kathrynmccloghry@bigpond.com](mailto:kathrynmccloghry@bigpond.com)

## Tesla's Longitudinal EM Waves

Dear NEXUS: I was interested by the mention of Tesla in the article by Gavin Dingley on ParaSETI/ET contact via subtle energies ["Harnessing the Universal Cosmic Energy", NEXUS 8/05–06], where Tesla was using a different type of radio than we use nowadays—i.e., using longitudinal electromagnetic waves instead of transverse waves.

I have something that ties into this. In an article I sent you some time ago, I described how to demonstrate the longitudinal wave nature of electromagnetic waves. The electronic device demonstrates an effect that Alexander Graham Bell showed.

An electronic device can be constructed, consisting of a photosensitive cell connected to a frequency-changing network connected to audio output speaker. The frequency changer is set to convert the frequencies at which light operates into audio sound level frequencies that the human ear is used to.

Once a light source is shone onto this device, sound comes out of it as light frequencies are converted into sound. The light source can be placed a very long distance away from the device and it still works.

The amazing feature is, if a sound is made at the light source, such as by a tuning fork or by someone speaking, then this sound is also

picked up by the device and comes out of the speaker. It does not seem to matter how far the sound source is away from the device: so long as it is between the path of the light source and the device, the sound is transmitted. (NB: the best light source is DC.)

Sound is a longitudinal wave, and so by its interaction with light it demonstrates that light has a longitudinal wave effect.

I have been looking into this sort of thing for some time now. If you are interested in a longer account of how this electromagnetic effect sits in with other things I have researched, then see below. Thanks.

Roger Anderton, R.J.Anderton@btinternet.com

## Secret Tunnels in Australia

Dear Duncan: I was interested to read the article on underwater bases and tunnels in the vol. 8, no. 5 issue. On a similar theme, a colleague of mine related the story of how he stumbled on something unusual.

He and a mate were driving from Coonabarabran to Narrabri on the Newell Highway, New South Wales, about 20 years ago. About halfway between the two towns, they stopped the car to "answer the call of nature". The road was isolated in tree and scrub country, there being no town, settlement or homestead anywhere nearby.

They descended the bank from the road and saw an open manhole amongst the trees, half hidden in the dappled shade. They moved to investigate. The manhole cover was hinged open, its upper surface covered in camouflage bark. The access shaft it had concealed went a short distance down.

Curious, my colleague and his friend climbed down the ladder to a round well-lit tunnel. Its diameter was much taller than they and was perfectly straight, vanishing into the distance on either side of them. The walls were of finished concrete and rails were set into the floor, perhaps for a goods/ passenger vehicle of some type. The two men chose not to explore further.

This tunnel was obviously not some cramped serviceway for telecommunications conduits. It was meant as a transport corridor, and, given the remote location of

# ... more Letters to the Editor

**NB: Please keep letters to approx. 150 to 250 words in length. Ed.**

this access point and the vast distances this tunnel system would have to cover, it was built at great expense. The obvious questions are: who built it and why? Does it lead to a secret underground base that is hardened against nuclear attack?

How many such facilities might be hidden in Australia, an island continent known for its empty and untraveller spaces?

[Name withheld by request.]

## Terrorism & the NWO Agenda

Dear Duncan: The tragedy of the recent attacks on the Pentagon and the World Trade Center buildings is different from what the "corrupt" media is making it out to be.

In mathematics,  $2 + 2 = 4$ . However, when it comes to all other matters, most people accept what the media are telling them, even though the facts do not add up.

In all legal matters, the first question that is normally asked is: what is the motive and who stands to benefit from the crime? In my opinion, it is crystal clear that the party(ies) benefiting from the terrorist crimes are the families that control the companies of the arms industry, who are also those of the banking sector and the media. Too much "education" may be a hindrance in understanding this.

Terrorist hijackers are pawns in the game (like the book), just like most people buying into the manipulations of the [New] World Order agenda from the corrupt media and politicians working against the US Constitution.

All hijackings which took place could not have happened without help from inside: US politicians swearing alliance to the Illuminati/World Order rather than the US Constitution?!

So, who are the real terrorists of this planet? And how interesting it is to hear a comment such as that made by George Bush, that the US is the beacon of light for the world. Which world is he talking about, and why would he use this phrase? How come the Statue of Liberty was not attacked, and what does the illuminating torch/flame stand for?

The scariest part of everything I have been talking about is not what

took place in New York and DC, but the fact that, as long as we buy into the lies of government and media, what has happened is just the beginning of high-financed terrorism by the "elite".

I hope that most Americans will wake up in time to see what was once a land of the free is no longer so. If the US falls, the rest of the "free" world falls.

Sincerely, from Canada, a reader that appreciates your magazine. A toast to freedom!

## Australian Free Energy Device

Dear Duncan: I know NEXUS has published many articles on free energy, but one I have been chasing up involves a generator invented by two Australians. It was demonstrated on TV—Channel 7's *Today Tonight* program—and written up in the *Cairns Post* on March 7, 2001. So far, I have seen no other mention of it but have been able to collect quite a lot of information.

The inventors, John Christie and Lou Brits, need A\$500,000 to build a plant in Cairns to develop their invention, but, as the US, Japan, China and Indonesia are all very interested, it would be a catastrophe if this self-powering unit were sold only overseas. We have thousands of places in Australia which could use this alternative source of energy; e.g., outback homesteads miles from power lines having to use oil or gas which is fast becoming too expensive to buy.

The generator runs virtually on perpetual motion, using magnets and a battery to kick-start it, and can produce enough electricity to power an entire house. The units could sell for from \$4,000 to \$5,000 and are transportable. Hope you can find space to do an article on it.

Good luck, and keep up the good work.

Yours sincerely,  
Shirley Campisi

[Dear Shirley: My opinion, after speaking to other researchers in this field including Robert Adams, is that the device created by Christie and Brits, which does work as claimed, appears to be very similar to the Adams Pulsed Electric Motor Generator. If this is true, then they may have some

trouble obtaining patents, as the Adams Motor information was put into the public domain by Robert Adams through NEXUS Magazine back in 1992. If they fail to obtain a patent, then it will be difficult to obtain large-scale funding, etc. I just hope they, and others, continue to succeed in their endeavours and that one day we'll all be using such devices. Ed.]

## An Ioniser that Really Works!

Dear Sir: I just wanted to write to you and let you know how pleased I am with one of the products advertised in NEXUS. I have collected a museum of ionisers and ozonators over the last 15 years and the *Elanra* is the best I have ever owned.

I have had problems breathing in the past, and air quality is very important to me. The *Elanra* is so far superior to every other ioniser on the market. I know, because I have owned every major brand and several MLM models. The price at first seemed expensive. As always, you get what you pay for. I brought three to four US\$100–\$300 [major brand] models and sent all of them back because they didn't do what they were claimed to do.

I knew within 24 hours of buying the *Elanra* that it was the best ioniser I had ever owned. I also started to wonder, after about three days of using the *Elanra*, whether all the other products were actually ionisers.

Thank you,  
Scott McCall, Longmont,  
Colorado, USA

## Spontaneous Combustion

People sometimes burn to death in the most extraordinary circumstances. Over the last 400 years, more than 200 people have burst into flames for reasons which have yet to be explained.

Contemporary reports all describe bodies totally consumed but arms and legs still intact, furniture close to the remains showing no signs of fire damage and a pink deposit found on light bulbs or similar shiny surfaces. The events usually take place at night, so eyewitnesses are few but they all speak of flames bursting forcefully outward from the body. Many people believe

these happenings must be examples of spontaneous human combustion.

I am investigating this mysterious phenomenon and invite correspondence from anyone who has personal experience of such events, especially those in Australia. A phone number/ address/email would be helpful, but anonymity is guaranteed if required. Many thanks.

G. Brice, 9 Kilsyth Court,  
Kallangur Qld 4503, Australia,  
gbrice@futureweb.com.au

## Health Concerns over GE Soy

Hi, NEXUS: I've just started reading Letters to the Editor, Oct–Nov 2001 issue [8/06], and thought I should write.

I have spent years in bed with ME or chronic fatigue syndrome. I have since found out that ME is really a strain of polio, and people can go down when their immune system is lowered—in my case, by sprays.

Now that I have some energy, I get very angry at the way farmers in this "clean, green" country spray family, friends, neighbours, animals, insects, birds and water life. They make Adolf Hitler look like an eco-friendly gentleman. Commonsense would tell you that these toxic chemicals in small doses must harm our bodies.

When I first got sick 16 years ago, I felt better eating sardines. Nowadays, if I eat sardines in soya oil I get a "dead" feeling. The same thing happened when I used some non-organic soya sauce and I realised that it is because it is now genetically engineered. I don't have to read about unknown effects: I know it's bad for you.

I have read the book *None Dare Call It Conspiracy* and realise that GE is just phase two of the insiders' efforts to reduce the population so they can take over the world. This book has changed the whole way I see the news.

The Arabs have said for years that astronauts never landed on the Moon and that the US is the Antichrist. The Bible says "whole nations will be deceived". I realise it's right, and not just about religion.

Pamela Mander

## ANTI-MMR VACCINE DOCTOR OUSTED

Dr Andrew Wakefield, the consultant gastroenterologist whose research has linked the MMR (measles, mumps, rubella) vaccine to autism and bowel disease, announced on December 1 that he had been asked to resign because of his work.

He had been testing the theory that measles virus from MMR vaccine can colonise the bowel of susceptible children, producing inflammatory bowel disease which then, via a disruption of the chemical balance in the body and the brain, leads to autism.

Dr Wakefield's departure comes a month after he was made a Fellow of the Royal College of Pathologists in recognition of his research work. Parents of autistic children involved in his research expressed their anger at the news. Some demanded reassurances that the Royal Free Hospital will continue treating their children.

Dr Wakefield told the *Telegraph* that he had seen almost 170 children with a similar story and claimed that the Department of Health's contention that MMR had been proven to be safe did not hold up.

Pressure on the children's gastroenterology unit is so great that its waiting list risks breaking the NHS's 18-month limit. (Source: *The Telegraph*, London, December 2, 2001, <http://news.telegraph.co.uk>)



## VOLCANIC ACTIVITY FOUND BENEATH ARCTIC ICE CAP

Under the frozen surface of the Arctic Ocean, scientists aboard a US Coast Guard icebreaker have unexpectedly discovered a searing cauldron of activity, including underwater volcanic movement and deep-sea hot springs.

Scientists have mapped and studied the Gakkel Ridge, which runs for 1,100 miles from north of Greenland to Siberia beneath the Arctic ice cap. This is the deepest and most remote portion of the global mid-ocean ridge system, where new ocean crust continuously is created as sea floor

spreading unfolds through volcanic activity. Defying expectations, the Gakkel Ridge appears to be highly volcanically active. The mission also retrieved evidence of a vast field of undersea vents known as "black smokers".

Gakkel Ridge is considered the world's slowest-spreading mid-ocean ridge. Because the southern end of the ridge spreads somewhat more quickly than the northern end, the scientists had expected that volcanic activity would peter out as they headed north. Instead, they discovered irregular pockets of volcanic activity rather than a uniform pattern.

(Source: *Reuters*, Nov. 28, 2001)

## DUTCH STUDY MAY PROVE EXISTENCE OF THE SOUL

A team of Dutch research doctors has conducted a study of 344 heart attack survivors and found that more than one in 10 of them had experienced "emotions, visions or lucid thoughts" while they were considered "clinically dead"—meaning that they were unconscious with no signs of pulse, breathing or brain activity at the time. Some of them reported having "out-of-body" experiences.

The survey took two years to conduct and is the largest study to date on the phenomenon of near-death experience (NDE).

The study itself raises some important questions about the continuation of consciousness after death and whether the mind and the brain can function independently. It also suggests the possibility of a spiritual component of human beings outlasting their mortal existence, and hints at the Universe being meaningful and not just random.

No doubt the debate about how to interpret the results of the study will continue for some time to come.

(Source: *The Lancet*, via the website [www.cosmiverse.com](http://www.cosmiverse.com), December 12, 2001)

## SOY ISOFLAVONES MAY PROMOTE BREAST CANCER

The increasingly consumed isoflavone, genistein—a plant oestrogen linked to the health benefits of soy, has been shown in a series of University of Illinois studies to stimulate the growth of oestrogen-dependent human breast cancer cells.

The findings of three studies, funded by



the National Institutes of Health, are detailed in the *Journal of Nutrition* (November 2001), *Carcinogenesis* (October 2001) and *Cancer Research* (July 2001).

The results demonstrate that genistein in various forms stimulates tumour growth. They also suggest that women with oestrogen-dependent breast cancer or a predisposition to it may want to reduce their consumption of soy products with a high isoflavone content.

Helferich in *Cancer Research*, compared soy protein isolates containing varying levels of isoflavones. The team found that oestrogen-dependent tumour growth increased as the isoflavone content increased in the soy-containing diet.

(Source: University of Illinois at Urbana-Champaign, Nov. 5, 2001, [www.uiuc.edu/](http://www.uiuc.edu/))

## FDA IGNORES EVIDENCE OF DANGEROUS NEW CHEMICALS IN IRRADIATED FOOD

The US Food and Drug Administration has ignored growing evidence that a new class of chemicals formed when food is irradiated could be harmful, according to a recent report released by Public Citizen and the Center for Food Safety.

The groups are urging the FDA to refrain from legalising irradiation for any additional types of food until the new chemicals are tested for safety.

The chemicals, called cyclobutanones, do not occur naturally anywhere on Earth. They recently were found to cause genetic damage in rats and genetic and cellular damage in human and rat cells.

The groups' report, "Hidden Harm", details how the FDA has ignored this unique class of chemicals, which are created in many irradiated foods that the agency has legalised for sale in the USA—including beef, pork, chicken, lamb, eggs, mango and papaya. It is expected that cyclobutanones also would be formed in many other foods the FDA is currently considering to legalise for irradiation.

The organisations today also released the sworn affidavit of toxicologist William Au, who was retained by the groups to review independently the risks posed by cyclobutanones and other chemicals formed by irradiation that could cause genetic damage.

Au, an environmental toxicology professor at the University of Texas Medical Branch in Galveston, is internationally

recognised for his work on the toxicological mechanisms that induce human disease. For more than 20 years he has taught, published peer-reviewed research and served on expert committees. He has received numerous awards and has written or co-written more than 100 published articles. "Without conclusive evidence regarding the safety of these products, the safety of irradiated food cannot be assured," he warned.

Au urged the FDA to "seriously and explicitly" consider "repeated observations" of genetic damage and reproductive toxicity in feeding experiments.

Though cyclobutanones were first identified in irradiated food in 1971, it was not until 1998 that German government scientists discovered that some types of cyclobutane, 2-DCB, caused genetic and cellular damage in human and rat cells.

Despite these findings, the FDA not only has failed to acknowledge publicly the potential risks posed by cyclobutanones; the agency also proceeded to legalise irradiation for three classes of food, even after the first two German studies were made public.

Ironically, cyclobutanones are so easily detectable and have been known to remain in food for such lengthy periods (more than a decade) that they are commonly used as "markers" to determine if food has been exposed to ionising radiation.

(Source: Dr Joseph M. Mercola, December 15, 2001, [www.mercola.com/2001/dec/15/irradiated\\_food.htm](http://www.mercola.com/2001/dec/15/irradiated_food.htm))

## ULTRASOUND CAUSES SUBTLE BRAIN DAMAGE IN BABIES

Evidence suggesting that ultrasound scans on pregnant women cause brain damage in their unborn babies has been uncovered by scientists.

In the most comprehensive study yet on the effect of the scanning, doctors have found that males born to mothers who underwent scanning were more likely to show signs of subtle brain damage.

A team of Swedish scientists has confirmed earlier reports on the effects of ultrasound, with the most compelling evidence yet that unborn (male) babies are affected by the scanning. They compared almost 7,000 men, whose mothers underwent scanning in the 1970s, with 170,000 men whose mothers did not, looking for differences in the rates of left- and right-handedness.

The team found that men whose mothers had scans were significantly more likely to be left-handed than normal, pointing to a higher rate of brain damage while in the womb. Crucially, the biggest difference was found among those born after 1975, when doctors introduced a second scan later in pregnancy. Such men were 32 per cent more likely to be left-handed than those in the control group.

Normally, left-handedness is genetic: the likelihood of two left-handed parents having a left-handed child is 35 per cent, while for two right-handed parents it is only nine per cent. It is when the incidence of left-handedness begins to rise



"You will travel to a mysterious, far-off, exotically beautiful land and carpet-bomb it."

above these normal rates that scientists become concerned that brain damage of some kind could be a factor.

The growing evidence that ultrasound affects unborn babies may cast new light on the puzzling rise in left-handedness over recent years.

(Source: by Robert Matthews, *Telegraph*, Dec. 20, 2001, [www.news.telegraph.co.uk](http://www.news.telegraph.co.uk))

## EURO BANKNOTES TO HAVE RADIO-FREQUENCY ID TAGS

According to an *EE Times* story published in December, the European Central Bank is working with technology partners on a hush-hush project to embed radio-frequency identification (RFID) tags into the fibres of euro banknotes by 2005.

A spokesman for the European Central Bank (ECB) in Frankfurt, Germany, confirmed the existence of a project but was careful not to comment on its technologies.

Although euro banknotes already include such security features as holograms, foil strips, special threads, microprinting, special inks and watermarks, the ECB believes it must add further protection to keep the euro from becoming the currency of choice in the criminal underworld.

"The RFID allows money to carry its own history" by recording information about where it has been, said Paul Saffo, Director of the Institute for the Future in Menlo Park, California.

Banknotes present "an interesting future application for us," said Tom Pounds, Vice President of RFID Projects at Alien

Technology, which holds the rights to a fabrication process that suspends tiny semiconductor devices in a liquid that's deposited over a substrate containing holes of corresponding shape. The devices settle on the substrate and self-align.

Rather than working on the interconnection to an RF antenna one chip at a time, "we can do a massively parallel interconnection," Pounds said. Banknotes are not Alien's primary focus at present, he said.

(Source: *EE Times*, December 19, 2001, [www.eetimes.com/story/OEG20011219S001](http://www.eetimes.com/story/OEG20011219S001))

## LOSS OF SUPERTANKERS AT SEA BLAMED ON GIANT WAVES

Scientists blame the disappearance of more than 200 supertankers and container ships during the past 20 years on monster waves of up to 36 metres in height.

A team of oceanographers at the Technical University in Berlin re-created in a tank the gigantic "one-off" seas that are capable of breaking a 180-metre-long ship in half.

"Even in the tank the effect was awe-inspiring," said the research leader, Günther Clauss. "The exploding wave was so powerful that it broke through the ceiling of the building in which the tank is located."

Using a computerised, hydraulically powered wave-making machine, Professor Clauss's team established that the monster waves could occur with little or no warning. He said slow-moving waves were caught up by a succession of faster waves

travelling at more than twice their speed.

"What happens then is that the waves simply pile up on top of each other to create a monster. The result is an almost vertical wall of water which towers up to 36 metres in height before collapsing on itself. Any vessel caught by one of these has little chance of surviving."

(Source: *Sydney Morning Herald*, January 10, 2002, [www.smh.com.au/news/0201/09/national/national18.html](http://www.smh.com.au/news/0201/09/national/national18.html))

## THERMAL DEVICE CAN DETECT LIES BY READING YOUR EYES

A new lie detector that measures sudden flashes of heat from around the eyes may soon be available.

"This is the first technology that allows lying to be measured or lying to be detected without any contact with the subject whatsoever, instantaneously, in real time," said lead researcher James Levine, an endocrinologist at the Mayo Clinic in Rochester, Minnesota.

"You don't need to hook them up to anything; you don't need any sophisticated experts to analyse the data."

"As people lie, there is a massive increase in blood flow around the eyes, and associated with that there is sudden warming around the eyes, where the colour changes to white in the thermal imaging system," Levine explained.

(Source: *UPI*, January 2, 2002)

## UN PROPOSAL TO REGISTER EVERY PERSON ON EARTH

A scheme whereby every person in the world would be fingerprinted and registered under a universal identification scheme has been put to a United Nations round-table meeting by Pascal Smet, the head of Belgium's independent Asylum Review Board.

Mr Smet said the European Union was already considering a Europe-wide system, using either fingerprints or eye-scanning technology to identify citizens, and said that the plan could be extended worldwide.

"If you look to our societies, we are already registered from birth until death. Our governments know who we are and what we are. But one of the basic problems is the numbers of people in the world who are not registered, who do not have a set identity, and when these people move with real or fake passports you cannot identify them.

(Source: *AAP*, December 13, 2001)

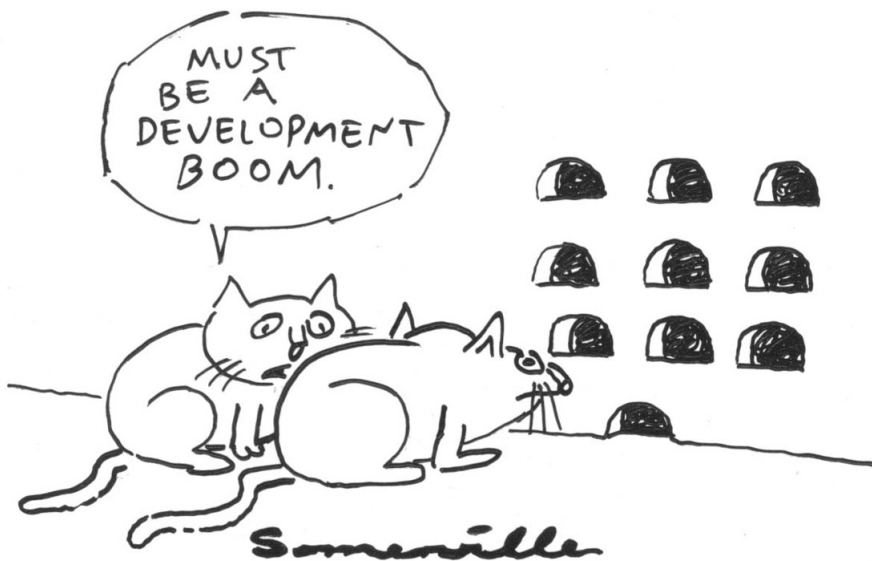



## A BAN ON WEAPONS IN SPACE?

The Space Preservation Act of 2001 (HR 2977), introduced as a Bill in the US House of Representatives on October 2, 2001 by Rep. Dennis Kucinich (D-OH), aims "To preserve the cooperative, peaceful uses of space for the benefit of all humankind by permanently prohibiting the basing of weapons in space by the United States, and to require the President to take action to adopt and implement a world treaty banning space-based weapons".

Note the following extracts from Section 7, Definitions: "(2)(A) The terms 'weapon' and 'weapons system' mean a device capable of any of the following: (i)(III) directing a source of energy (including molecular or atomic energy, subatomic particle beams, electromagnetic radiation, plasma, or extremely low frequency [ELF] or ultra low frequency [ULF] energy radiation) against [an] object; or (IV) any other unacknowledged or as yet undeveloped means. (IV)(ii) Inflicting death or injury on, or damaging or destroying, a person (or the biological life, bodily health, mental health or physical and economic well-being of a person)—(I) through the use of any of the means described in clause (i) or subparagraph (B); (II) through the use of land-based, sea-based or space-based systems using radiation, electromagnetic, psychotronic, sonic, laser or other energies directed at individual persons or targeted populations for the purpose of information war, mood management or mind control of such persons or populations; or (III) by expelling chemical or biological agents in the vicinity of a person.

(B) Such terms include exotic weapons systems such as (i) electronic, psychotronic or information weapons; (ii) chemtrails; (iii) high-altitude ultra low frequency weapons systems; (iv) plasma, electromagnetic, sonic or ultrasonic weapons; (v) laser weapons systems; (vi) strategic, theatre, tactical or extraterrestrial weapons; and (vii) chemical, biological, environmental, climate or tectonic weapons.

(C) The term 'exotic weapons systems' includes weapons designed to damage space, natural ecosystems (e.g., the ionosphere and upper atmosphere) or climate, and weather and tectonic systems with the purpose of inducing damage or destruction upon a target population or region on Earth or in space."

(Source: *Secrecy News*, January 10, 2002, [www.fas.org](http://www.fas.org))

## AUSTRALIA'S DOMESTIC INTELLIGENCE AGENCY, ASIO, TO BE GIVEN UNPRECEDENTED POWERS

A further boost to Australia's political police agencies, including unprecedented powers to detain people secretly without charge, has become a major item in the Howard government's agenda for the new year.

At its last Cabinet meeting for 2001, on December 18, the government approved "a raft of measures" under the pretext of combatting terrorism. It also announced a summit of federal and state government leaders in March to strengthen and possibly restructure the police and intelligence forces.

The Cabinet confirmed a plan, first unveiled in the wake of the September 11 attacks in the United States, to allow the Australian Security Intelligence Organisation (ASIO) to detain and interrogate for 48 hours anyone whom it suspects of involvement in terrorism or of having any information about terrorism.

Detainees will be held incommunicado, unable to contact their families and denied access to legal advice or representation. ASIO will not have to specify a charge or produce evidence, yet any prisoner who refuses to answer its questions can be imprisoned for five years.

Working in conjunction with state and federal police, ASIO will be able to have people picked up, brought before a tribunal and ordered to provide information or hand over documents, even if they are not themselves suspected of terrorist activity. These provisions could easily be used against journalists and political activists.

According to Attorney-General Daryl Williams, "terrorism" will be re-defined so that it includes an act or omission "for a political, religious or ideological purpose designed to intimidate the public with regard to its security and intended to cause serious damage to persons, property or infrastructure". The criminal code will also cover aiding, abetting, conspiracy, attempt and incitement, with all these offences carrying a maximum penalty of life imprisonment.

These provisions are so sweeping that they could cover a range of dissenting political activity, including protests and the distribution of literature. Moreover, collection, receipt or provision of funds for the preparation and planning of terrorism, or knowingly assisting any of these activities, will be punishable by a prison sentence of up to 25 years.

ASIO and other intelligence and police agencies will be given powers to access unread emails, allowing them to act on the basis of messages that the alleged recipient has not even seen. They will also be permitted to share information on terrorism and alleged financial links with equivalent agencies overseas. ASIO will receive extra funding and resources, unspecified as yet, and "Cabinet will give further consideration to a range of additional measures" in the new year.

Over the past two decades, ASIO has already been handed powers to tap phones, intercept email and mail, plant tracking devices on people or vehicles and install listening devices in offices and homes. It can easily obtain secret search-and-entry warrants, and physically or electronically break into computer files and databases.

This is not the first time that governments have seized upon the alleged threat of terrorism to expand ASIO's powers. The first ASIO Act was passed in 1979 in the wake of the 1978 attempted bombing of the Hilton Hotel in Sydney during a Commonwealth Heads of Government meeting. The federal Fraser government, joined by the Wran government in New South Wales, declared that "the age of terrorism" had arrived in Australia. That bombing remains unsolved to this day, but it led to two police frame-ups of members of the Ananda Marga religious sect. Sect members spent years in prison before the frame-ups were exposed, leaving all the evidence pointing to the bomb having been planted by ASIO itself, or another police agency.

In 1999, the Howard government cited fears of terrorism at the Sydney 2000 Olympic Games as a pretext for giving ASIO further sweeping powers. No terrorist activity eventuated, but ASIO's powers—including to hack into computers, access taxation files and plant secret tracking devices—have remained. The government also used the Games as a pretext to pass legislation providing for the military to be called out against domestic political unrest.

(Source: by Mike Head via *World Socialist Web Site*, [WSWS.org](http://WSWS.org), December 27, 2001, [www.wsws.org/articles/2001/dec2001/asio-d27.shtml](http://www.wsws.org/articles/2001/dec2001/asio-d27.shtml))







# THE HEALTH-SUPPORTING BENEFITS OF COCONUTS

**Coconuts and coconut oil contain health-promoting saturated fatty acids and derivative compounds which have powerful antimicrobial properties.**

**Part 1 of 2**

**by Mary G. Enig, PhD, FACN**  
© 1999, 2001

Director  
Nutritional Sciences Division  
Enig Associates, Inc.  
12501 Prosperity Drive, Suite 340  
Silver Spring, MD 20904-1689, USA  
Telephone: +1 (301) 680 8600  
Fax: +1 (301) 680 8100  
Email: marye@enig.com

*The following is the text of a talk and paper, "Coconuts: In Support of Good Health in the 21st Century", presented by Dr Mary Enig at the Asian Pacific Coconut Community (APCC) meeting held in Pohnpei in the Federated States of Micronesia in 1999. Note that it does make several references to animal experiments, and that NEXUS does not condone animal experimentation. Editor.*

## ABSTRACT

Coconuts play a unique role in the diets of mankind because they are the source of important physiologically functional components. These physiologically functional components are found in the fat part of whole coconut, in the fat part of desiccated coconut and in the extracted coconut oil.

Lauric acid, the major fatty acid from the fat of the coconut, has long been recognised for the unique properties that it lends to nonfood uses in the soaps and cosmetics industry. More recently, lauric acid has been recognised for its unique properties in food use, which are related to its antiviral, antibacterial and antiprotozoal functions. Now, capric acid, another of coconut's fatty acids, has been added to the list of coconut's antimicrobial components. These fatty acids are found in the largest amounts only in traditional lauric fats, especially from coconut. Also, recently published research has shown that natural coconut fat in the diet leads to a normalisation of body lipids, protects against alcohol damage to the liver and improves the immune system's anti-inflammatory response.

Clearly, there has been increasing recognition of the health-supporting functions of the fatty acids found in coconut. Recent reports from the US Food and Drug Administration about required labelling of the *trans* fatty acids will put coconut oil in a more competitive position and may help its return to use by the baking and snack-food industry, where it has continued to be recognised for its functionality. Now it can be recognised for another kind of functionality: the improvement of the health of mankind.

## I. INTRODUCTION: BENEFITS OF COCONUT OIL SATURATES

Mr Chairman and members of the Asian Pacific Coconut Community: I would like to thank you for inviting me once again to speak to this gathering of delegates on the occasion of your 36th session as you celebrate the 30th anniversary of APCC.

When I addressed the 32nd Cocotech meeting in Cochin, India, I covered two areas of interest to the coconut community. In the first part, I reviewed the major health challenge facing coconut oil at that time, which was based on a supposed negative role played by saturated fat in heart disease. I hope that my talk was able to dispel any acceptance of that notion. In the second part of my talk, I suggested that there were some new, positive health benefits from coconut which should be recognised. These benefits stemmed from coconut's use as a food with major functional properties for antimicrobial and anti-cancer effects.

In my presentation today, I will bring you up to date about the new recognition of "functional foods" as important components in the diet. Additionally, I would like to review briefly the state of the anti-saturated fat situation and bring you up to date on some of the research that compares the beneficial effects of saturated fats with those of omega-6 polyunsaturates, as well as the beneficial effects of the saturated fats relative to the detrimental effects of the partially hydrogenated fats and the *trans* fatty acids. In particular, I will review some of the surprising beneficial effects of the special saturates found in coconut oil as they compare with those of the unsaturates found in some of the other food

oils. Components of coconut oil are increasingly being shown to be beneficial. Increasingly, lauric acid and even capric acid have been the subject of favourable scientific reports on health parameters.

## II. FUNCTIONAL PROPERTIES OF LAURIC FATS AS ANTIMICROBIALS

Earlier this year, at a special conference entitled "Functional Foods For Health Promotion: Physiologic Considerations" (Experimental Biology '99, Renaissance Washington Hotel, Washington, DC, April 17, 1999), which was sponsored by the International Life Sciences Institute (ILSI) North America, Technical Committee on Food Components for Health Promotion, it was defined that "a functional food provides a health benefit over and beyond the basic nutrients".

This is exactly what coconut and its edible products such as desiccated coconut and coconut oil do. As a functional food, coconut has fatty acids that provide both energy (nutrients) and raw material for antimicrobial fatty acids and monoglycerides (functional components) when it is eaten. Desiccated coconut is about 69% coconut fat, as is creamed coconut. Full coconut milk is approximately 24% fat.

Approximately 50% of the fatty acids in coconut fat are lauric acid. Lauric acid is a medium-chain fatty acid which has the additional beneficial function of being formed into monolaurin in the human or animal body. Monolaurin is the antiviral, antibacterial and antiprotozoal monoglyceride used by the human (and animal) to destroy lipid-coated viruses such as HIV, herpes, cytomegalovirus, influenza, various pathogenic bacteria including *Listeria monocytogenes* and *Helicobacter pylori*, and protozoa such as *Giardia lamblia*. Some studies have also shown some antimicrobial effects of the free lauric acid.

Also, approximately 6–7% of the fatty acids in coconut fat are capric acid. Capric acid is another medium-chain fatty acid which has a similar beneficial function when it is formed into monocaprin in the human or animal body. Monocaprin has also been shown to have antiviral effects against HIV and is being tested for antiviral effects against herpes simplex and for antibacterial effects against *Chlamydia* and other sexually transmitted bacteria (Reuters, London, June 29, 1999).

The food industry has, of course, long been aware that the functional properties of the lauric oils, and especially coconut oil, are unsurpassed by other available commercial oils. Unfortunately in the United States, during the late 1930s and again during the 1980s and 1990s, the commercial interests of the domestic fats and oils industry were successful in driving down usage of coconut oil. As a result, in the US and in other countries where the influence from the US is strong, the manufacturer has lost the benefit of the lauric oils in its food products.

As we will see from the data I will present in this talk, it is the consumer who has lost the many health benefits that can result from regular consumption of coconut products.

The antiviral, antibacterial and antiprotozoal properties of lauric acid and monolaurin have been recognised by a small number of researchers for nearly four decades. This knowledge has resulted in more than 20 research papers and several US patents, and last year it resulted in a comprehensive book chapter which reviewed the important aspects of lauric oils as antimicrobial agents (Enig, 1998). In the past, the larger group of clinicians and food and nutrition scientists has been unaware of the potential benefits of consuming foods containing coconut and coconut oil, but this is now starting to change.

Kabara (1978) and others have reported that certain fatty acids (FAs) (e.g., medium-chain saturates) and their derivatives (e.g., monoglycerides, MGs) can have adverse effects on various microorganisms. Those microorganisms that are inactivated include bacteria, yeast, fungi and enveloped viruses. Additionally, it is reported that the antimicrobial effects of the FAs and MGs are additive, and total concentration is critical for inactivating viruses (Isaacs and Thormar, 1990).

The properties that determine the anti-infective action of lipids are related to their structure, e.g., monoglycerides, free fatty acids. The monoglycerides are active; diglycerides and triglycerides are inactive. Of the saturated fatty acids, lauric acid has greater antiviral activity than caprylic acid (C-8), capric acid (C-10) or myristic acid (C-14).

In general, it is reported that the fatty acids and monoglycerides produce their killing/inactivating effect by lysing the plasma membrane lipid bilayer. The antiviral action attributed to monolaurin is that of solubilising the lipids and phospholipids in the envelope of the virus, causing the disintegration of the virus envelope. However, there is evidence from recent studies that one antimicrobial effect in bacteria is related to monolaurin's interference with signal transduction (Projan et al., 1994), and another antimicrobial effect in viruses is due to lauric acid's interference with virus assembly and viral maturation (Hornung et al., 1994).

Recognition of the antiviral aspects of the antimicrobial activity

of the monoglyceride of lauric acid (monolaurin) has been reported since 1966. Some of the early work by Hierholzer and Kabara (1982), which showed virucidal effects of monolaurin on enveloped RNA and DNA viruses, was done in conjunction with the Centers for Disease Control of the US Public Health Service. These studies were done with selected virus prototypes or recognised representative strains of enveloped human viruses. The envelope of these viruses is a lipid membrane, and the presence of a lipid membrane on viruses makes them especially vulnerable to lauric acid and its derivative, monolaurin.

The medium-chain saturated fatty acids and their derivatives act by disrupting the lipid membranes of the viruses (Isaacs and Thormar, 1991; Isaacs et al., 1992). Research has shown that enveloped viruses are inactivated in both human and bovine milk by added fatty acids and monoglycerides (Isaacs et al., 1991) and also by endogenous fatty acids and monoglycerides of the

**Unfortunately in the United States, during the late 1930s and again during the 1980s and 1990s, the commercial interests of the domestic fats and oils industry were successful in driving down usage of coconut oil.**

appropriate length (Isaacs et al., 1986, 1990, 1991, 1992; Thormar et al., 1987).

Some of the viruses inactivated by these lipids, in addition to HIV, are the measles virus, herpes simplex virus-1 (HSV-1), vesicular stomatitis virus (VSV), visna virus and cytomegalovirus (CMV). Many of the pathogenic organisms reported to be inactivated by these antimicrobial lipids are those known to be responsible for opportunistic infections in HIV-positive individuals. For example, concurrent infection with cytomegalovirus is recognised as a serious complication for HIV-positive individuals (Macallan et al., 1993).

Thus, it would appear to be important to investigate the practical aspects and the potential benefits of an adjunct nutritional support regimen for HIV-infected individuals, which will utilise those dietary fats that are sources of known antiviral, antimicrobial and antiprotozoal monoglycerides and fatty acids such as monolaurin and its precursor, lauric acid.

Until now, no one in the mainstream nutrition community seems to have recognised the added potential of antimicrobial lipids in the treatment of HIV-infected or AIDS patients. These antimicrobial fatty acids and their derivatives are essentially nontoxic to man; they are produced *in vivo* by humans when they ingest those commonly available foods that contain adequate levels of medium-chain fatty acids such as lauric acid. According to the published research, lauric acid is one of the best "inactivating" fatty acids, and its monoglyceride is even more effective than the fatty acid alone (Kabara, 1978; Sands et al., 1978; Fletcher et al., 1985; Kabara, 1985).

The lipid-coated (enveloped) viruses are dependent on host lipids for their lipid constituents. The variability of fatty acids in the foods of individuals, as well as the variability from *de novo* synthesis, accounts for the variability of fatty acids in the virus envelope and also explains the variability of glycoprotein expression—a variability that makes vaccine development more difficult.

Monolaurin does not appear to have an adverse effect on desirable gut bacteria but, rather, only on potentially pathogenic micro-organisms. For example, Isaacs et al. (1991) reported no inactivation of the common *Escherichia coli* or *Salmonella enteritidis* by monolaurin, but major inactivation of *Hemophilus influenzae*, *Staphylococcus epidermidis* and group B gram-positive *Streptococcus*.

The potentially pathogenic bacteria inactivated by monolaurin include *Listeria monocytogenes*, *Staphylococcus aureus*, *Streptococcus agalactiae*, groups A, F and G streptococci, gram-positive organisms, and some gram-negative organisms if pre-treated with a chelator (Boddie and Nickerson, 1992; Kabara, 1978, 1984; Isaacs et al., 1990, 1992, 1994; Isaacs and Schneidman, 1991; Isaacs and Thormar,

1986, 1990, 1991; Thormar et al., 1987; Wang and Johnson, 1992).

Decreased growth of *Staphylococcus aureus* and decreased production of toxic shock syndrome toxin-1 was shown with 150 mg monolaurin per litre (Holland et al., 1994). Monolaurin was shown to be 5,000 times more inhibitory against *Listeria monocytogenes* than is ethanol (Oh and Marshall, 1993). *Helicobacter pylori* was rapidly inactivated by medium-chain monoglycerides and lauric acid, and there appeared to be very little development of resistance of the organism to the bactericidal effects of these natural antimicrobials (Petschow et al., 1996).

A number of fungi, yeast and protozoa have been found to be inactivated or killed by lauric acid or monolaurin. The fungi include several species of ringworm (Isaacs et al., 1991). The yeast reported is *Candida albicans* (Isaacs et al., 1991). The protozoan parasite *Giardia lamblia* is killed by free fatty acids and monoglycerides from hydrolysed human milk (Hernell et al., 1986; Reiner et al., 1986; Crouch et al., 1991; Isaacs et al.,

1991). Numerous other protozoa were studied with similar findings, but these have not yet been published (Jon J. Kabara, private communication, 1997).

Research continues in measuring the effects of the monoglyceride derivative of capric acid, monocaprin, as well as the effects of lauric acid. *Chlamydia trachomatis* is inactivated by lauric acid, capric acid and monocaprin (Bergsson et al., 1998). Hydrogels containing monocaprin are potent *in vitro* inactivators of sexually transmitted viruses such as HSV-2 and HIV-1 and bacteria such as *Neisseria gonorrhoeae* (Thormar, 1999).

### III. ORIGINS OF THE ANTI-SATURATED FAT, ANTI-TROPICAL OILS AGENDA

The coconut industry has suffered more than three decades of abusive rhetoric from the consumer activist group Centers for

**Components of coconut oil, such as lauric acid, are increasingly being shown to be beneficial.**

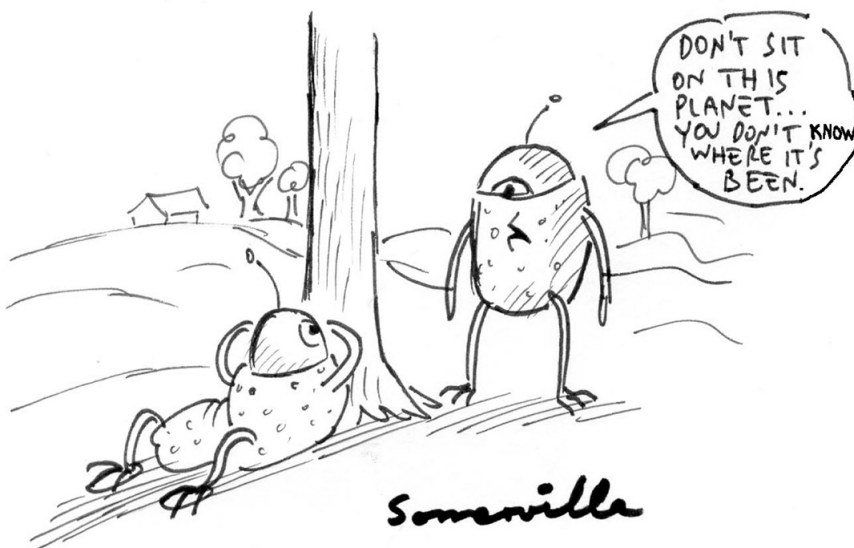

Science in the Public Interest (CSPI), from the American Soybean Association (ASA) and other members of the edible oil industry, and from those in the medical and scientific community who learned their misinformation from groups like CSPI and ASA. I would like to review briefly the origins of the anti-saturated fat, anti-tropical oil campaigns and hopefully give you some useful insight into the issues.

When and how did the anti-saturated fat story begin? It really began in part in the late 1950s, when a researcher in Minnesota announced that the heart disease epidemic was being caused by hydrogenated vegetable fats. The edible oil industry's response at that time was to claim it was only the saturated fat in the hydrogenated oils that was causing the problem. The industry then announced that it would be changing to partially hydrogenated fats and that this would solve the problem.

In actual fact, there was no change because the oils were already being partially hydrogenated and the levels of saturated fatty acids remained similar, as did the levels of the *trans* fatty acids. The only thing that really changed was the term for "hydrogenation" or "hardening" listed on the food label.

During this same period, a researcher in Philadelphia reported that consuming polyunsaturated fatty acids lowered serum cholesterol. This researcher neglected, however, to include the information that the lowering was due to the cholesterol going into the tissues such as the liver and the arteries. As a result of this research report and the acceptance of this new agenda by the domestic edible oils industry, there was a gradual increase in the emphasis on replacing "saturated fats" in the diet and on consuming larger amounts of the "polyunsaturated fats".

As many of you probably know, this strong emphasis on consuming polyunsaturates has backfired in many ways. The current adjustments, being recommended in the US by groups such as the National Academy of Sciences, replace the saturates with mono-unsaturates instead of with polyunsaturates and replace polyunsaturates with mono-unsaturates.

Early promoters of the anti-saturated fat ideas included companies such as Corn Products Company (CPC International), through a book written by Jeremiah Stamler in 1963, with the professional edition published in 1966 by CPC. This book took some of the earliest pejorative stabs at the tropical oils. In 1963, the only tropical fat or oil singled out as high in saturated fats was coconut oil. Palm oil had not entered the US food supply to any extent, had not become a commercial threat to the domestic oils and was not recognised in any of the early texts.

The editorial staff of *Consumer Reports* noted that "...in 1962...one writer observed, the average American now fears fat [saturated fat, that is] 'as he once feared witches'".

In 1965, a representative of Procter & Gamble Pharmaceuticals told the American Heart Association to change its diet/heart statement to remove any reference to the *trans* fatty acids. This altered official document encouraged the consumption of partially hydrogenated fats. In the 1970s, this same Procter & Gamble employee served as nutrition chairman in two controlling positions for the National Heart, Lung, and Blood Institute's Lipid

Research Clinic (LRC) trials and as director of one of the LRC centres. These LRC trials were the basis for the 1984 NIH Cholesterol Consensus Conference, which in turn spawned the National Cholesterol Education Program (NCEP). This program encourages consumption of margarine and partially hydrogenated fats, while admitting that *trans* should not be consumed in excess. The official NCEP document states that "coconut oil, palm oil, and palm kernel oil...should be avoided".

In 1966, the US Department of Agriculture documents on fats and oils talked about how unstable the unsaturated fats and oils were. There was no criticism of the saturated fats. That criticism of saturated fats was to come later to this agency when it came under the influence of the domestic edible fats and oils industry and when it developed the US Dietary Guidelines. These Dietary Guidelines became very anti-saturated fat and remain so to this day. Nevertheless, as we will learn later in my talk, there started some reversal of the anti-saturated fat stance in the works of this agency in 1998.

In the early 1970s, although a number of researchers were voicing concerns about the *trans* fats, the edible oil industry and the

US Food and Drug Administration (FDA) were engaging in a revolving-door exchange that would promote the increasing consumption of partially hydrogenated vegetable oils, condemn the saturated fats and hide the *trans* issue. As an example of this "oily" exchange, in 1971 the FDA's general counsel became president of the edible oil trade association, the Institute of Shortening and Edible Oils (ISEO), and he in turn was replaced at the FDA by a food lawyer who had represented the edible oil industry.

From that point on, the truth about any real effects of the dietary fats had to play catch-up. The

American edible oil industry sponsored "information" to educate the public, and the natural dairy and animal fats industries were inept at countering any of that misinformation. Not being domestically grown in the US, coconut oil, palm oil and palm kernel oil were not around to defend themselves at that time. The government agencies responsible for disseminating information ignored those protesting "lone voices", and by the mid-1980s American food manufacturers and consumers had made major changes in their fats and oils usage—away from the safe, saturated fats and headlong into the problematic *trans* fats.

Enig and Fallon (1998-99) have reviewed the above history in "The Oiling of America", published in NEXUS Magazine [see 6/01-2]. This article can be viewed and downloaded from the NEXUS website at [www.nexusmagazine.com/OilingAmerica.1.html](http://www.nexusmagazine.com/OilingAmerica.1.html) and [www.nexusmagazine.com/OilingAmerica.2.html](http://www.nexusmagazine.com/OilingAmerica.2.html).

#### IV. THE DAMAGING ROLE OF THE US CONSUMER ACTIVIST GROUP CSPI

Some of the food oil industry members—especially those connected with the American Soybean Association and some of the consumer activists (particularly the Centers for Science in the Public Interest and also the American Heart Savers Association) further eroded the status of natural fats when they sponsored the major anti-saturated fat, anti-tropical oils campaign in the late 1980s.

**As many of you probably know,  
this strong emphasis on  
consuming polyunsaturates has  
backfired in many ways.**



Actually, an active anti-saturated fat bias started as far back as 1972 at the CSPI. But beginning in 1984, this very vocal consumer activist group started its anti-saturated fat campaign in earnest. In particular at this time, the campaign was against the "saturated" frying fats, especially those being used by fast-food restaurants. Most of these so-called saturated frying fats were tallow-based, but also included was palm oil in at least one of the hotel/restaurant chains.

Then, in a critical "News Release" in August 1986—"Deceptive Vegetable Oil Labeling: Saturated Fat Without The Facts"—CSPI referred to "palm, coconut and palm kernel oil" as "rich in artery-clogging saturated fat". CSPI further announced that it had petitioned the Food and Drug Administration to stop allowing labelling of foods as having "100% vegetable shortening" if they contained any of the "tropical oils". CSPI also asked for the mandatory addition of the qualifier, "a saturated fat", when coconut, palm or palm kernel oil was named on the food label.

In 1988, CSPI published a booklet called "Saturated Fat Attack". This booklet contains lists of processed foods "surveyed" in Washington, DC, supermarkets. The lists were used for developing information about the saturated fat in the products. Section III is entitled "Those Troublesome Tropical Oils" and it contains statements encouraging pejorative labelling. There were lots of substantive mistakes in the booklet, including errors in the description of the biochemistry of fats and oils and completely erroneous statements about the fat and oil composition of many of the products.

At the same time that CSPI was conducting its campaign in 1986, the American Soybean Association began its anti-tropical oils campaign by sending inflammatory letters, etc., to soybean farmers. The ASA took out advertisements to promote a "[tropical] Fat Fighter Kit". The ASA hired a Washington, DC, "nutritionist" to survey supermarkets to detect the presence of tropical oils in foods.

Then, early in 1987, the ASA petitioned the FDA to require labelling of "tropical fats". In mid-1987 the *Soybean Digest* was continuing an active and increasing anti-tropical oils campaign.

At about the same time, the *New York Times* (June 3, 1987) published an editorial, "The Truth About Vegetable Oil", in which it called palm, palm kernel and coconut oils "the cheaper, artery-clogging oils from Malaysia and Indonesia" and claimed that US federal dietary guidelines opposed tropical oils, although it is not clear that this was so. The "artery-clogging" terminology was right out of CSPI.

Two years later, in 1989, the ASA held a press conference with the help of the CSPI in Washington, DC, in an attempt to counter a press conference held on March 6 by the palm oil group. The ASA "Media Alert" stated that the National Heart, Lung, and Blood Institute and National Research Council "recommend consumers avoid palm, palm kernel and coconut oils".

Only months before these press conferences, millionaire Phil Sokolof, the head of the National Heart Savers Association (NHSA), purchased the first of a series of anti-saturated fats and anti-tropical fats advertisements in major newspapers. No one has found an overt connection between Sokolof (and his NHSA) and the ASA, but the CSPI bragged about being his adviser.

## V. USE OF COCONUT OIL IN THE PREVENTION AND TREATMENT OF HEART DISEASE

The research over four decades concerning coconut oil in the diet and heart disease is quite clear: coconut oil has been shown to be beneficial in combatting/reducing the risk factors in heart disease. This research leads us to ask the question, "Should coconut oil be used both to prevent and treat coronary heart disease?" This is based on several reviews of the scientific literature concerning the feeding of coconut oil to humans.

Blackburn et al. (1988) reviewed the published literature of "coconut oil's effect on serum cholesterol and atherogenesis" and concluded that when "fed physiologically with other fats or adequately supplemented with linoleic acid, coconut oil is a neutral fat in terms of atherogenicity".

After reviewing this same literature, Kurup and Rajmohan (1995) conducted a study on 64 volunteers and found "no statistically significant alteration in the serum total cholesterol, HDL cholesterol, LDL cholesterol, HDL cholesterol/total cholesterol ratio and LDL cholesterol/HDL cholesterol ratio of triglycerides from the baseline values". A beneficial effect of adding the coconut kernel to the diet was noted by these researchers.

Kaunitz and Dayrit (1992) reviewed some of the epidemiological and experimental data regarding coconut-eating groups and noted that the "available population studies show that dietary coconut oil does not lead to high serum cholesterol nor to high coronary heart disease mortality or morbidity".

They noted that, in 1989, Mendis et al. reported undesirable lipid changes when young adult Sri

Lankan males were changed from their normal diets by the substitution of corn oil for their customary coconut oil. Although the total serum cholesterol decreased 18.7% from 179.6 to 146.0 mg/dL and the LDL cholesterol decreased 23.8% from 131.6 to 100.3 mg/dL, the HDL cholesterol decreased 41.4% from 43.4 to 25.4 mg/dL (putting the HDL values very much below the acceptable lower limit of 35 mg/dL) and the LDL/HDL ratio increased 30% from 3.0 to 3.9. These latter two changes are considered quite undesirable.

Mendis and Kumarasunderam (1990) also compared the effect of coconut oil and soy oil in normolipidemic young males, and again the coconut oil resulted in an increase in the HDL cholesterol, whereas the soy oil reduced this desirable lipoprotein.

As noted above, Kurup and Rajmohan (1995), who studied the addition of coconut oil alone to previously mixed fat diets, had reported no significant difference from baseline.

**The research over four decades concerning coconut oil in the diet and heart disease is quite clear: coconut oil has been shown to be beneficial in combatting/reducing the risk factors in heart disease.**

Previously, Prior et al. (1981) had shown that islanders with high intakes of coconut oil showed "no evidence of the high saturated fat intake having a harmful effect in these populations". When these groups migrated to New Zealand, however, and lowered their intake of coconut oil, their total cholesterol and LDL cholesterol increased and their HDL cholesterol decreased. Statements that any saturated fat is a dietary problem is not supported by evidence (Enig, 1993).

Studies that allegedly showed a "hypercholesterolemic" effect of coconut oil feeding usually only showed that coconut oil was not as effective at lowering the serum cholesterol as was the more unsaturated fat to which coconut oil was being compared. This appears to be in part because coconut oil does not "drive" cholesterol into the tissues as do the more polyunsaturated fats. The chemical analysis of the atheroma showed that the fatty acids from the cholesterol esters are 74% unsaturated (41% of the total fatty acids is polyunsaturated) and only 24% are saturated. None of the saturated fatty acids was reported to be lauric acid or myristic acid (Felton et al., 1994).

There is another aspect to the coronary heart disease picture. This is related to the initiation of the atheromas that are reported to be blocking arteries. Recent research shows that there is a causative role for the herpes virus and cytomegalovirus in the initial formation of atherosclerotic plaques and the relogging of arteries after angioplasty (*New York Times*, January 29, 1991). What is so interesting is that the herpes virus and cytomegalovirus are both inhibited by the antimicrobial lipid monolaurin, but monolaurin is not formed in the body unless there is a source of lauric acid in the diet.

Thus, ironically enough, one could consider the recommendations to avoid coconut and other lauric oils as contributing to the increased incidence of coronary heart disease.

*Chlamydia pneumoniae*, a gram-negative bacterium, is another of the micro-organisms suspected of playing a role in atherosclerosis by provoking an inflammatory process that would result in the oxidation of lipoproteins with induction of cytokines and production of proteolytic enzymes—a typical phenomenon in atherosclerosis (Saikku, 1997). Some of the pathogenic gram-negative bacteria with an appropriate chelator have been reported to be inactivated or killed by lauric acid and monolaurin as well as capric acid and monocaprin (Bergsson et al., 1997; Thormar et al., 1999).

However, the micro-organisms which are most frequently identified as probable causative infecting agents are in the herpes virus family and include cytomegalovirus, type 2 herpes simplex (HSV-2) and Coxsackie B4 virus.

The evidence for a causative role for cytomegalovirus is the strongest (Ellis, 1997; Visseren et al., 1997; Zhou et al., 1996; Melnick et al., 1996; Epstein et al., 1996; Chen and Yang, 1995), but a role for HSV-2 is also shown (Raza-Ahmad et al., 1995).

All members of the herpes virus family are reported to be

killed by the fatty acids and monoglycerides from saturated fatty acids ranging from C-6 to C-14 (Isaacs et al., 1991), which include approximately 80% of the fatty acids in coconut oil.

In spite of what has been said over the past four or more decades about the culpability of the saturated fatty acids in heart disease, they are ultimately going to be held blameless. More and more research is showing the problem to be related to oxidised products. The naturally saturated fats such as coconut oil are one protection we have against oxidised products.

**Thus, ironically enough, one could consider the recommendations to avoid coconut and other lauric oils as contributing to the increased incidence of coronary heart disease!**

**Continued in the next issue of NEXUS Magazine**

#### **Editor's Note:**

As we have insufficient space to publish the numerous references accompanying this article, we have instead posted them on the NEXUS Magazine website, [www.nexusmagazine.com](http://www.nexusmagazine.com).

#### **About the Author:**

Dr Mary G. Enig holds an MS and PhD in Nutritional Sciences from the University of Maryland in the USA. She is a consulting nutritionist and biochemist of international renown and an expert in fats/oils analysis and metabolism, food chemistry and composition and nutrition and dietetics.

Dr Enig is Director of the Nutritional Sciences Division of Enig Associates, Inc., President of the Maryland Nutritionists Association and a Fellow of the American College of Nutrition. She is also Vice President of the Weston A. Price Foundation and

Science Editor of the Foundation's publication. Dr Enig has many years of experience as a lecturer and has taught graduate-level courses for the Nutritional Sciences Program at the University of Maryland, where she was a Faculty Research Associate in the Lipids Research Group, Department of Chemistry and Biochemistry, University of Maryland. She also maintains a limited clinical practice for patients needing nutritional assessment and consultation.

Dr Enig has extensive experience consulting and lecturing on nutrition to individuals, medical and allied health groups, the food processing industry and state and federal governments in the US. She also lectures and acts as a consultant to the international health and food processing communities. Since 1995 she has been invited to make presentations at scientific meet-

ings in Europe, India, Japan, Vietnam, Indonesia, the Philippines and Micronesia.

Dr Enig is the author of numerous journal publications, mainly on fats and oils research and nutrient/drug interactions. She also wrote the book *Know Your Fats* (Bethesda Press, Silver Spring, MD, May 2000). She is a popular media spokesperson and was an early critic speaking out about the use of *trans* fatty acids and advocating their inclusion in nutritional labelling.

One of Dr Enig's recent research topics dealt with the development of a nutritional protocol for proposed clinical trials of a non-drug treatment for HIV/AIDS patients. Her articles, "The Oiling of America" and "Tragedy and Hype: The Third International Soy Symposium", written with nutritionist/researcher Sally Fallon, were published in NEXUS 6/01-2 and 7/03 respectively.





# PROJECT HAMMER

## Covert Finance and the Parallel Economy

*Off-ledger trading programs run by some central and international banks have been used to manipulate the price of gold and channel funds into covert government operations.*

*Part 2 of 2*

by David G. Guyatt © 2001

c/- NEXUS Office  
55 Queens Road  
East Grinstead, W. Sussex RH19 1BG  
United Kingdom  
Email: goldbug@goldbug99.  
freeserve.co.uk  
Website: www.deepblacklies.co.uk

### ILLUMINATI INTRIGUE AND "BLACK" GOLD COLLATERAL

The gold "connection" remains unclear. However, there is reason to suppose that the dollar "assets" that date back to the 1940s and 1950s, as earlier discussed by General Erle Cocke, may relate in part to vast quantities of gold looted during World War II by the Japanese plunder teams (known as the Golden Lily) and also by the Nazis in Europe.

That substantial amounts of gold bullion were ransacked and then hidden throughout the Philippines prior to war's end is now undeniable. This, however, was "black" gold—meaning it did not appear on official statistics or in treasury department lists.

Santa Romana was an OSS officer operating in the Philippines during the war and learned where the Japanese had buried plundered gold and other valuables. But there are other aspects to the Santa Romana gold story that are only now coming to the surface. They reveal a shocking secret that, if true, could shake the foundations of our belief and change the way we view the world we live in.

According to Santa Romana's widow, Luz, her husband told her that he was a member of the Illuminati—a very secretive elite group that dates back to 1776 when it was founded by Adam Weishaupt at the University of Ingolstadt, Germany. According to those who have researched it, the purpose of the Illuminati was to set in motion, in secret, a New World Order of world revolution.

This, however, does not fully tally with what Santa Romana told his wife about them. According to Luz, the purpose of the Illuminati was based on the knowledge that the royal families of Europe were aware that they were losing political and effective control of their nations. But it was the possible loss of control over the wealth of their kingdoms that bothered them most. Consequently, they founded the Illuminati and set in motion long-term plans aimed at secretly taking control of world finances, especially gold and other precious metals.

In time, the royal families who sat at the centre of the Illuminati movement were forced to expand and take into membership political and business leaders. At some point in the early 20th century, two 50-year plans were set in motion, aimed at cornering the world's precious metal reserves.

The foregoing is the account given to Luz by her husband Santa Romana. How true it is remains to be seen, and it is not hard to view it as disinformation told by Santa Romana to his wife to conceal his real motives—whatever they may have been.

More intriguing still is Luz's account that her late husband was the one-time "head" of the Trilateral Commission—an elite group which is known to have tentacles deeply embedded in the Marcos gold story of later years. Again, there is no corroborating evidence, and the fact that the Trilateral Commission was founded only in 1973, whereas Santa Romana died in 1974, suggests this is unlikely.

However, it is more than a little curious that whilst Santa Romana eventually (and undoubtedly) came to control the great bulk of gold that resulted from plunder during WWII, he did have substantial gold deposits dating back further than that.

Papers relating to the "estate" of Santa Romana purport to show a gold account at the Union Bank of Switzerland, Zurich, containing 8,000 metric tonnes valued at US\$10 billion. The account dates back to 1920. Such a quantity of gold dating from that period represents a massive holding, far surpassing that held today by the world's leading central banks.

It is also at least interesting—again, according to the account of his wife—that Santa Romana as a young boy was adopted by his great uncle in Hawaii who was married to the last Hawaiian princess. The couple had remained childless throughout their marriage, leading to the decision to adopt the young Santa Romana. According to Luz, it was this "royal" connection that gave Santa Romana entrée into the Illuminati.

Interestingly, during the course of my ongoing investigation into Project Hammer, a number of others involved in this program whom I have spoken with have told me, quite independently of the Santa Romana story, that the Hammer program—and numerous other collateral trading programs associated with it—have enormously powerful "gold trusts" of royal origin sitting behind them.

Perhaps the Hammer program was meant to generate enough money to buy substantial quantities of black gold stashed in the Philippines to ensure it be kept out of circulation, thus protecting the gold price to some degree. Perhaps it had more to do with the secret acquisition of vast amounts of this black gold in line with what Santa Romana told his wife. Perhaps the assets in question were not just gold but included pre-war US Treasury obligations (bonds and notes) that are now coming to light in the Philippines but which are said by US authorities to be fraudulent. Whatever is the case, it is certain that substantial quantities of "black" gold are used to underpin (collateralise) certain trading programs, and the funds thus generated are earmarked for use in other secretive operations.

This whole subject remains an ongoing investigation. The deeper I dig, the murkier it becomes. Stories are commonplace of warehouses full of banknotes waiting to be laundered by a trading program so that they can re-enter the financial system as clean as a whistle. Foreign exchange transactions involving billions of dollars in equivalent currency and which trade at huge discounts—unknown in the official marketplace—are also not uncommon. It is also a fact that many of those involved in trading programs are members of government intelligence and security organisations.

### **SOUTH AFRICAN INTELLIGENCE AND THE STASI**

Another individual who has played a considerable role in Project Hammer is the South African Rolf van Rooyen, who operated a number of business entities including one called Oceantech and another called Eastech International Bank. At one time van Rooyen worked for South African intelligence, and he is also believed to have been CIA at the time Project Hammer was in process.

Of significance is the fact that General Cocke and van Rooyen knew each other, although Cocke says he only spoke to him on the phone but never "shook hands with him". When questioned about Project Hammer during a police interview in Germany in 1995, van Rooyen gave this response:

"If you are referring to Operation Hamer [*sic*], it is an extremely large, very delicate operation in cooperation with the authorities of various countries in which Oceantech is involved."

Van Rooyen then proceeded to identify "America, England, Germany, France, Italy..." as being involved. He also told German police that from the very first day he began investigating Project Hammer:

**"We realised that it was a direct state matter and that the USA, the CIA and several other groups in the Secret Service were involved, as well as very, very high-coupled people in the American Government."**

"We realised that it was a direct state matter and that the USA, the CIA and several other groups in the Secret Service were involved, as well as very, very high-coupled people in the American Government."

The latter are rumoured to include George H. W. Bush, James Baker III, Former Treasury Secretary Lloyd Bentsen and Federal Reserve Chairman Alan Greenspan.

During his deposition, Erle Cocke was asked if he considered van Rooyen's foregoing statement to be accurate. Cocke replied, saying: "He is not too far off. I am sure he flavoured it up a little bit, yes."

Working alongside van Rooyen was South African intelligence operative Riaan Stander. Both Stander and van Rooyen were board members of the Eastcorp Syndicate, which boasted almost two dozen other companies in its stable.<sup>4</sup> Included were Intercol Pty Ltd, Cavo Shipping, which conducted intelligence-gathering missions for governments, and Bridge SA, which was registered in Monrovia, Liberia.

According to Peter Goslar, once a close friend of Riaan Stander, other board members of Bridge SA were Colonel Tim Spicer and Mick Ranger "of Sandline fame". In a letter written to

a Washington law firm involved in a Project Hammer lawsuit, Goslar fingers Bridge SA—and hence van Rooyen and Riaan Stander—as "part of the Executive Outcomes operation".

But there is more. During several daylong meetings I had with Peter Goslar in late June 2001, he handed me hundreds of pages of documents he had retrieved from Riaan Stander's private papers. These included documents showing a Mexican entity called Ro-Mar Pharmaceuticals, which van Rooyen told German police was the "money power" behind Eastech

International Bank. The money Ro-Mar Pharmaceuticals claimed to control was represented by over US\$100 billion in gold. Other papers clearly show van Rooyen and Stander engaged in collateral trading programs involving Latin American governments, most notably Argentina—once the preferred bolt-hole of notorious Nazis like Martin Bormann.

Another document from the batch I received from Peter Goslar was a list of companies grouped under the heading "United Kingdom Network", and this "network" was identified as being part of The Palace Group. An interesting description, I think. In any event, listed under this "group" were 24 business entities including Sandline International, Diamond Works, Branch Mining Ltd and Bridge International. The list also included Defence Systems Ltd as a part of The Palace Group and identified it as a division of Vickers—Britain's oldest and most distinguished armaments manufacturer, which resides at the very centre of the United Kingdom's Establishment.

During one of our meetings, Peter Goslar told me he was a personal acquaintance (perhaps even a friend) of former East German spy-master Marcus Wolf, who headed the East German security apparatus known as the Stasi. Peter also claimed to know several former Stasi operatives. He also spoke German fluently in addition to Afrikaans and his native English tongue.

Later I was told that a Peter Goslar was briefly mentioned in the autobiography written by Marcus Wolf, entitled *Man Without A Face*. Discussing the fall from grace of West German Chancellor Helmut Schmidt in 1977 following the discovery that his personal

secretary, Dagmar Kahlig-Scheffler, was a spy working for the Stasi, Wolf explains that Chancellor Schmidt's spy-cum-secretary was caught when her Stasi control officer Peter Goslar came under suspicion by West German counterintelligence.

I asked Peter if he was the same Peter Goslar identified by his "friend" Marcus Wolf and he denied this. Nonetheless, he told me that Rolf van Rooyen was still living in Germany and was under the protection of two former Stasi agents. And we do know that the Stasi worked closely and in the shadows with South African intelligence on a variety of projects, mostly weapons-related. Curious.

The Palace Group, meanwhile, contains all the guile and charm of a privatised off-the-books appendage of Britain's Secret Intelligence Service (SIS).

On the other side of the Atlantic, General Cocke and his firm Cocke & Phillips International have many similarities with its foregoing British cousin and probably was (and is, as the firm remains active) one of the CIA's private off-the-books companies. This conclusion is not only drawn from Cocke's affiliation with the known CIA entity Nugan Hand Bank, but another CIA front company called Associated Traders Corporation.

ATC, as it is known, came into brief prominence some years ago following a series of articles written by syndicated columnist Jack Anderson, naming Associated Traders as a gun-running, money-laundering, "off-the-books" CIA front. Then, in 1988, a US\$4 million lawsuit was filed that involved ATC. By 1990, the Director of the CIA, William Webster, issued an affidavit calling for a sweeping gag order to be slapped on the lawsuit on the grounds of national security. Of interest is the fact that more than one source has told me that Associated Traders Corporation was General Cocke.

The foregoing connections could easily be typified as part of the Anglo-American-African covert intelligence relationship that continues to conceal many sins.

There is reason to suppose that part of the funds derived from the Project Hammer financial trading program went to fund certain military and intelligence operations in South Africa. These are thought to have included financing of the so-called "Hammer units" that are alleged to have engaged in brutal beatings and assassinations throughout South Africa prior to the collapse of the apartheid regime. It is also believed that Hammer funds were used to finance the purchase of arms given to the Inkatha Freedom Party, which was engaged in widespread acts of bloody violence during 1992 and 1993—as discussed in the 1994 Report of the Goldstone Commission of Inquiry that named Eastech, van Rooyen and Stander.

Another aspect of Project Hammer may have involved the desire to plunder South Africa of much of its available mineral wealth prior to the country's coming under control of the ANC in 1994. In the hard-hitting and suppressed book *Glitter and Greed*,

written by Australian investigative reporter Janine Roberts, the Oppenheimer family and De Beers arranged that a "...fabulous multibillion Rand stockpile of the finest gems was shipped out prior to the 1994 elections, and that the mines producing the best gems were put into overdrive in both South Africa and Namibia so that as many as possible of the better gems were extracted as fast as possible."<sup>15</sup> I have also been told that large quantities of South African gold were also surreptitiously shipped out of South Africa at around this time—presumably for similar reasons.

It is also of interest to note that mounting evidence points to the conclusion that since 1995 the price of gold has been kept purposefully low as a result of a conspiracy engineered by the US Treasury Department in collaboration with leading international banks. The result has been that the cost of extracting gold for many South African gold mines is no longer cost-effective.

Could some of this alleged "missing" South African gold be related to a transaction that van Rooyen and Stander entered into in 1991? This involved Eastech International Bank's agreeing to purchase 5,000 metric tonnes of gold at a 4% discount from the prevailing Second London Fix—at a cost of about US\$50 billion. This gold was held in the free zone area beneath Zurich's Kloten Airport. The contract, which was to be governed by the "canton laws of Zurich", runs to six pages and each page bears the official stamp of the Swiss police, authorising and validating the transaction.

It remains unclear if van Rooyen and Stander were acting on their own behalf or were fronting for someone else in this transaction. Van Rooyen, at least, has been fingered as a CIA asset in addition to his having South African intelligence affiliations. Might they have been operating as a "deniable cut-out" for the US Treasury Department who wished to get delivery of this gold?

Perhaps the Chinese Government was party to the transaction instead. Eastech International Bank was, after all, a wholly owned subsidiary of Sino-Eastech, an entity which van Rooyen told German police investigators was "established in China" and which "operates from Xin Xong and was originally established by the

General Staff of the 7th military power in China". In operating their bank, van Rooyen and Stander liaised with a Chinese Army General whom van Rooyen declined to name, saying he wasn't "sure what his name is". His German police interrogator, displaying a well-honed sense of official disinterest in such diplomatic incongruities, rapidly moved on to other issues.

By 1995, Eastech International Bank had begun to hit the radar screen of regulatory authorities around the world, which viewed it with suspicion. But by then it seems probable that much of Project Hammer's South African objectives had been fulfilled. Fearing the worse, Rolf van Rooyen left South Africa and travelled to Germany. And according to his one-time friend Peter Goslar, that is where he still lives—albeit protected by former members of East Germany's Stasi spy network.

**Interestingly, during the course of my ongoing investigation into Project Hammer, a number of others involved in this program whom I have spoken with have told me that the Hammer program—and numerous other collateral trading programs associated with it—have enormously powerful "gold trusts" of royal origin sitting behind them.**

It remains to be seen whether the sanctions-busting objective of the South African end of Project Hammer was a simple case of certain elites making sure they got all the mineral wealth they needed from South Africa before turning the country over to the ANC and Nelson Mandela in 1994. What is known is that, beginning in 1995, the price of gold entered a new round of price manipulation which continues to this day.

Over the last two years, the Gold Anti-Trust Action (GATA) group has demonstrated that the manipulation of the gold price has been orchestrated by the US Federal Reserve working in collusion with leading Wall Street and international banks. Many of those banks quoted by GATA as being party to the price manipulation conspiracy—for that is what it amounts to—are also major players in trading programs.

In any event, the depressed price of gold has made many South African mines uneconomic to operate, and one cannot help but ask if this was by design. Southern hemisphere nations may sit on much of the mineral wealth of the planet, but the northern hemisphere industrialised nations appear intent on continuing to control and exploit it.

#### **MORE "BLACK" GOLD**

Project Hammer and the Jacobe program have the appearance of being "umbrella" operations geared, in the narrow sense at least, to generating funds for particular authorised projects. Once the proper authorisation has been issued, programs such as these seem to broaden in scope and greater effort goes towards creating deniable slush funds for use in any number of ways as the occasion demands. When you think about it, this makes considerable sense for those who engage in the game of black operations and political manipulation.

In addition to its authorisation to repatriate dollars dating back to the 1940s and 1950s, as explained by General Cocke, could Project Hammer have had other purposes? For example, could it have been used to finance another project—one that had specific East German connotations and which might explain the Stasi connection more fully?

It is certainly interesting that on 6 February 1989, the French Central Bank, the Banque de France, issued an International Certificate of Deposit for 620,000 kilograms of 99.99% pure gold. At that time, 620 metric tonnes of gold had a market value of about US\$7 billion. A king's ransom.

The certificate is almost identical to dozens I have on file and which I have written about and also reproduced in my book, *The Secret Gold Treaty*. As I explain there, certificates of this nature invariably contain spelling mistakes or other obvious typographical flaws which can be used to deny the validity of the certificate in the event it ever reaches public attention.

This was a technique developed by Britain's secretive Special Operations Executive (SOE) in WWII. SOE agents, parachuted into France and elsewhere in occupied Europe, were taught to insert pre-arranged spelling errors into messages they sent by

radio in the event they were captured by the Nazis. This would immediately alert SOE that the agent was in custody and that German counterintelligence wished to use the agent to feed false information back to HQ.

In any event, the Banque de France certificate mentioned above was in the name of Erich Honecker, the then East German head of state (see exhibits). Six months later, in a trumpet of media coverage, Honecker was ousted from power. A month after that, the Berlin Wall—the very symbol of Communism throughout the world—was opened. The opening was abruptly followed by its complete demolition at the hands of a euphoric public. Germany, which had been divided for over 30 years, was at last reunified.

By many accounts, Project Hammer began trading in November 1989 but was set up a lot earlier than that. Few of those involved in the transaction on the periphery know for certain what assets were used to collateralise it, although black gold has been mentioned in numerous telephone conversations and correspondence. But all parties are certain that an element of the backing collateral was cash.

What we do know is that Citibank had accounts in the name of José Diaz and Severino Santa Romana. These were billion accounts dating back to the years that Santa Romana, General Edward Lansdale and others were engaged in recovering gold stashed in the Philippines by the Japanese plunder teams, the Golden Lily.

At some point in history, some of Santa Romana's gold was converted to cash. This, along with gold and other plunder, was deposited in well over a hundred bank accounts located in over 40 countries throughout the world. These were the deniable assets that made up a particular CIA slush fund, known to insiders in the black gold market as the Black Eagle Fund—a name that was based on the symbol of the Nazi eagle. Some of these assets were placed under the control of the late Baron von Krupp, whose personal attorney, Carl Hermann Letemeyer, of the private Zurich-based law firm of Senn, Christians & Letemeyer, handled the Baron's

estate following his death.

Documents I published in *The Secret Gold Treaty* reveal that out of a fortune of just over US\$12 trillion which the late Baron controlled, slightly over \$110 billion was earmarked for one Clemente Santiago, a relative of Candelaria Santiago who was the "most trusted lady" of the late President Marcos of the Philippines.

Baron Krupp's incredible fortune was undoubtedly largely composed of Santa Romana's plunder, later acquired by deception by President Marcos, who had earlier been Santa Romana's lawyer in the Philippines prior to his rise to political office. In reality, stories about "Marcos gold" speak of Santa Romana's gold and the OSS/CIA's gold—although Marcos did recover vast quantities for himself via a Philippine Army battalion dedicated to locating and recovering WWII plunder.

**How would G7 governments explain to a cynical public that decades of drug money and illegal weapons sales proceeds had been laundered with their blessing (albeit in secret) in order to win the Cold War and also to artificially prop up a political system that we call Capitalism, which would otherwise collapse under its own inherent flaws?**

**Continued on page 82**







# THE BIBLE FRAUD

***The Church went out of its way to suppress the knowledge that Jesus had an identical twin brother, Judas Thomas, and that their father was Tiberius, who later became Emperor of Rome.***

***Part 2 of 3***

**by Tony Bushby © 2001**

Extracted from chapters 2 and 3  
of his book

***The Bible Fraud***

Published in 2001 by  
The Pacific Blue Group Inc., Hong Kong

Website: [www.thebiblefraud.com](http://www.thebiblefraud.com)

## THE ROMAN FATHER OF THE TWINS

As with ancient Hebrew, Christian and Jewish names, it is also difficult to be exactly sure of the real names of many of the Roman characters with which we are dealing and many irregularities arise. The allocation of names was unlike today's Western procedure, and a great many were purposely compounded with the names of Caesars, deities and hybrid variations such as Caracalla, Emperor of Rome, AD 211–217. "Caracalla" was a name derived from a long tunic worn by the Gauls, which he adopted as his favourite dress after he became Emperor. His proper name was Marcus Aurelius Antoninus.

The name Caesar developed from "caesarian", being the nature of the birth of Julius Caesar. Sometimes a new name was afterwards substituted for the original one, just as Plato was originally called Aristocles. The Jewish name of the first-century historian Joseph ben Matthias became Titus Flavius Josephus when he took Roman citizenship late in life.

A popular loan-name among Roman men was Silvanus,<sup>39</sup> which developed from the Roman god of "uncultivated land beyond the boundaries of tillage". A man with the name of Silvanus was depicted as "uncanny and dangerous". In many cases the name was not given until the person was grown up, and it was then adapted from personal qualities, such as Modestus, Servus ("from a servile condition"), or the name of an historical celebrity, Cornelia being one instance. In another Roman tradition, the name was sometimes a reference to peculiar circumstances at birth, e.g., Lucius, born by day; Manius, born in the morning; Alphus, the first born; Quintus, the fifth born; and Decimus, the tenth born. As a rule, the eldest received the praenomen (Christian name) of his father, and this helps to determine exactly who Tiberius Julius Abdes Panthera, as it appears on the headstone at Bingerbrück in Germany, really was.

The name Tiberius Julius is the first part of the full name of Tiberius, Emperor of Rome,<sup>40</sup> the adopted son and heir of Emperor Augustus. Whether Tiberius was a native of Sidon in Phoenicia, as recorded on the headstone, is difficult to establish for there are conflicting references to his birthplace. When he was very young, Tiberius' parents were in fear of their lives through the uncertainty of the civil war, where wrong political allegiances could result in early death.

*His childhood and youth were beset with hardships and difficulties, because Claudius Nero and Livia [his parents] took him wherever they went in their flight from Octavius... He was next hurried all over Sicily... His parents finally fled to Greece but were still in pursuit...escaping with him from Sparta at night.<sup>41</sup>*

The *Monumentum Ancyranum*<sup>42</sup> reports that at one stage the family sailed from Phoenicia to Egypt to avoid persecution. With such persistent pursuers it was probable that the family lived at Sidon in Phoenicia and left when they were found, but this information was not publicly recorded.

The words that are important in establishing whether or not the headstone actually referred to Emperor Tiberius are "Panthera" and "Abdes". In order to understand this inscription, it shall be shown that the headstone was composed well after the time of the events in question and therefore benefited from the hindsight of history. There appeared to be a very deliberate plan in place in the manufacture of this headstone, and whoever was responsible for its construction knew the essence of what is revealed in this book. Its unknown creator encoded vital information in the form of a cipher and anagram, which

when decoded revealed the identity of the father of Mariamne Herod's twin boys.

In many cases a name was a reflection of that person's character, and that view of ancient understanding can be used to trace an individual's life and illuminate that person's intimate character peculiarities. That was the case with Tiberius Julius' nickname, Panther. Variations were Panter, Panetier, Panterer (Roman), which all meant "adulterer"<sup>43</sup> and Tiberius was a man noted for his sexual excesses. This was an indication of how historical characters received their confusing multiplicity of names, for their names came to reflect their nature and the events that surrounded their lives.

Not even Tiberius' friends would deny that he often committed adultery, but said in justification that he did so for reasons of state, not simple passion: he wanted to discover what his enemies were doing by becoming intimate with their wives or daughters.<sup>44</sup> The reputation of being a womaniser stuck to Tiberius, and as an elderly man he was said to have still harboured "a passion for deflowering girls, indulging in his sensual propensities on the island of Capri". The name of Panther may have originally developed from a little-known ancient Roman city of debauchery called Pantherin or Pantherine. "Panther" may have also been attached to Tiberius Julius because of his beastly nature for the cat-like tactics he used in stalking and pouncing on his opponents in wars against the Dalmatians and Pannonians.

*In the old Physiologus [an anonymous second-century book of 50 allegories], the panther was the type of Christ, but later, when the savage nature of the beast became more widely known, it became symbolical of evil and hypocritical flattery.*<sup>45</sup>

From the year of his adoption by Augustus, circa AD 4, to the death of that Emperor, Tiberius was in command of the Roman armies and because of his wicked nature his troops named him "the savage beast".<sup>46</sup> Modern historians describe him as a bloody tyrant.

There may be another clue in the name "Panther" associated with the lusty, untamed, horned Greek god Pan, who amused himself with the chase of nymphs. He was forever in love with one nymph or another, but always rejected because of his foul nature. Pan dwelt in forests and was dreaded by those whose occupations caused them to pass through the woods by day or night. Hence sudden fright without any visible cause was ascribed to Pan and called a "panic" terror. This blackened his image so that he was seen to correspond to the Devil himself. The name "Pan" may have originally developed from the earlier Greek myth of Pandarus, the term meaning "he who shoots an arrow". Pan was the bowman (archer) of the zodiac, which is also the sign of Sagittarius, encompassing parts of the months of November and December, and it was no surprise to find that Tiberius, an archer in his youth,<sup>47</sup> was born in November. There does seem to be some historical doubt as to accuracy of the time and place of his birth, and this may account for the modern birth date given to him—16 November<sup>48</sup>—falling slightly outside the prescribed range of the current Sagittarius dates, 26 November to 23 December.

It should be recognised, however, that the calendar has been adjusted over the course of 2,000 years. Some time shortly before

the 17th century, the Latin Sacred College quietly restored fifteen years to the Roman calendar. The net result of that and earlier alterations shows a present difference between Oriental and Western chronologies of sixty-three years when both are compared from any certainly known astronomical date—for example, Halley's comet.

The Roman leaders were renowned for their personification of earlier gods, and the story of Julius Caesar acting out the role as Zeus was well recorded.

*Then there was Augustus' private banquet, known as "The Feast of the Divine Twelve", which caused a public scandal. The guests came dressed as gods or goddesses, Augustus himself representing Apollo.*<sup>49</sup>

Apollo was the son of Zeus, who was the equivalent to Jupiter in the Roman pantheon, with the "Divine Twelve" representing the gods of the zodiac. Zeus was also the father of Hermes and Pan was Hermes' son. The great importance of the gods in Roman history at the time was seen when Emperor Augustus enlarged the temple of Apollo near Nicopolis, built in recognition of the victory at Actium.<sup>50</sup> This was the victory over Mark Antony that cleared the way for his imperial dictatorship.

Abdes was the third name found on the tombstone and applied to Tiberius Julius Panthera. The origin of Abdes may be connected with Emperor Augustus' liking for ciphers, and this may be what the originator of the tombstone was alluding to when he applied it to Tiberius. It was said of Emperor Augustus that:

*Instead of paying strict regard to orthography, as formulated by the grammarians, he inclined towards phonetic spelling... When Augustus wrote in cipher he simply substituted the next letter of the alphabet for the one required, except that he wrote AA for X.*<sup>51</sup>

**"Abdes" was the third name found on the tombstone and applied to Tiberius Julius Panthera.**

By applying both of these rules to the word "Abdes" on the German headstone, a hidden code is thus revealed:

*Abdes = Ab-des = Bc-des = BC days*

(Note: The extra twist for the reader is to apply the cipher rule forward as the person creating it, not backwards as would have been the case to decipher.)

The person or persons who created the headstone cipher could have only done so after the sixth century when the Julian calendar was instituted.

The proposed suggestion is that the cipher was designed to draw attention to the fact that circumstances surrounding the fathering and birth of Mariamne Herod's twin boys occurred in BC rather than AD. Presumably the inscription on the tombstone was placed there to convey a special message, for it is unlikely to have been put there 600 years or more after the actual event to honour the site of an actual body, if there ever was a body buried at the site.

The inscription stated that Tiberius Julius Abdes Panthera was transferred to service in the Rhineland (Germany) in the year AD 9. The young Tiberius was indeed in that area at that time.

*Tiberius was given another three years of tribunicial power, with the task of pacifying Germany... There followed the*

*Illyrian revolt, which he was sent to suppress... Tiberius conducted it for three years...but, though often called back to Rome... Tiberius was well paid for his stubbornness, by finally reducing the whole of Illyricum—an enormous stretch of country enclosed by northern Italy, Noricum, the Danube, Thrace, Macedonia and the Adriatic Sea—to complete submission.*<sup>52</sup>

This timely victory prevented the victorious Germans, who had defeated three legions of Rome under Varus in AD 9, from linking up with the Pannonians.

*Proposals were made for decreeing him [Tiberius] the surname "Pannonicus", or "the Unconquered" or "the Devoted"; but Emperor Augustus vetoed all these in turn, promising on each occasion that Tiberius would be satisfied with that of "Augustus", which he intended to bequeath him.*<sup>53</sup>

The evidence is compelling in locating Tiberius for service in the area of the Rhineland in AD 9. However, to switch the era from AD to BC as the Abdes cipher suggests, the person named on the headstone was in the Rhineland in 9 BC, not AD, and Tiberius was located there on active duty at that time also. Suetonius recorded that "in the third [instance] he

took some 40,000 German prisoners, whom he brought across the Rhine and settled in new homes on the Gallic bank",<sup>54</sup> the years verified as 7 and 9 BC. Although Tiberius was on active duty in that area at that time, "he visited Rome several times".<sup>55</sup>

The date, nevertheless, is curious for locating the tombstone at Bingerbrück at all, because it does not say that Tiberius Julius Abdes Panthera died and was buried there; only that he was on service in the Rhineland. The evidence of the assertion supposes that this time of 9 BC is a coded message revealing the year the twin boys were born to Mariamne Herod. At that time, she would have been fifteen years of age.

The territory known as Germany today was never identified with this title until at least the time of Napoleon, when the Confederation of the Rhine was formed in July 1806. From that time on, the area began to be called Rhineland. This knowledge brings the placing of the tombstone forward some 1,200 additional years from the first-century designation and nearly 1,800 years after the death of Tiberius.

On further examination, a remarkable materialisation of information appeared, for on a modern map of Germany we find that Bingerbrück is located on the Rhine River in the Rhineland Palatinate, a district of southwest Germany west of the Rhine, which belonged to Bavaria until 1945. Formerly, portions of the neighbouring territory (Upper Palatinate) constituted an electorate of the Holy Roman Empire, now part of the Rhineland Palatinate State. The Latin-derived word Palatinate was a different sense of the word Palatine, whereas the

Latin *Palatinus* meant "of the Imperial House" and the electorate indicated the state contained one of the German princes entitled to elect the Emperor of the Holy Roman Empire.<sup>56</sup>

Palatine is one of the Seven Hills of Rome and was where the Emperor of the Roman Empire resided in the Imperial House—succeeded by the Emperor of the Holy Roman Empire who now resides in the Vatican. The interesting matter is that in earlier times there was built on the Palatine hill a shrine to "The Heavenly Twins", and it remains there to this day.

### Conclusion

The cipher on the Bingerbrück headstone connected the ancient Panthera tradition of the Rabbinic writings with the first-century Roman Emperor Tiberius. The conclusion drawn is that by reason of her mother's friendship with Emperor Augustus, the teenage Mariamne Herod met Tiberius when he returned to Rome to see his Emperor father early in 9 BC, and her twin sons were conceived by rape or adultery by him at that time. It was possible Mariamne Herod was then married, for the traditions of the time accepted the early marriage of girls. The eldest daughter of Agrippa I, for example, was married at the age of thirteen.<sup>57</sup>

Mariamne Herod named her sons Judas and Yeshu'a and the populace subsequently nicknamed them "ben

Panthera" ("son of Panthera") after their "adulterer" father. The name Yeshu'a came to be pronounced and spoken as "Jesus" in English-language translations, and to avoid confusion shall be used as such throughout this work.

Unravelling the headstone cipher has now completed a full circle, beginning with the illegitimate birth of twin boys to Mariamne Herod, the Virgin Mary of the Gospels, and ending with their father being the thirty-three-year-old Tiberius who became Emperor of Rome in AD 14.

The two boys, although illegitimate by birth, were the legitimate heirs to the throne—the next in line to the imperial purple toga—and that is exactly what the Gospels of the New

**Unravelling the headstone cipher has now completed a full circle, beginning with the illegitimate birth of twin boys to Mariamne Herod, the Virgin Mary of the Gospels...**

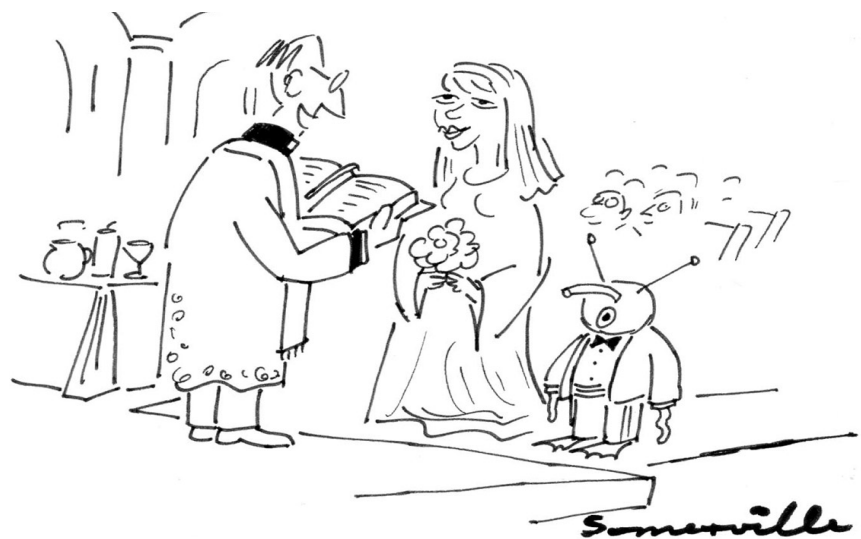

*"And do you, Gorppp, promise to love, honour and transmogrify molecularly so long as you both shall live?"*

Testament record. This leads to an underlying truth hidden below the surface level of the Gospel story, and is one that the Church has suppressed for 1,700 years.

The Gospel of Mark suggests Judas and Jesus were commonly regarded as illegitimate by the people of their time. The fact that they were each identified as a "son of Mary" (Mark 6:3), not a "son of Joseph", was interpreted by scholars to mean Judas and Jesus were regarded at the time as Mary's illegitimate sons.

In the Gospel of John (8:41), the scribes and Pharisees challenged Jesus about his birth—"We are not born of fornication"—again revealing that the general populace knew that Jesus' birth, and thus Judas', was illegitimate. Related, in Luke 4:22, was Jesus' irritated reaction to the words, "Is not this Joseph's son?" Why would Jesus (or maybe it was Judas speaking) react to this seemingly harmless question? The answer was documented in the oldest Greek texts of the New Testament which read, "not son of Joseph, this one".

The scriptural and historical data being presented in this work show that the New Testament was never an authentic record, but was in its entirety a corpus of corrupted documents specifically constructed to induce a particular belief (John 20:30–31).

This conclusion rests firmly on known facts, and the ensuing chapters analyse ancient Roman, British and Church reports that support this assertion.

## THE HIDDEN TWIN

The premise for the conclusion in this work is that the "ben Panthera" twins were of royal birthright and legitimate contenders to the throne of Palestine and the Emperorship of Rome. The Gospel appellations "king of the Jews" and "son of God" were correct titles because of the tradition of the times and the identity of both the mother and father.

The boys were "brought up by Augustus Caesar",<sup>58</sup> their grandfather, and at least one of the boys publicly called himself the "son of God" and "son of the archangel".<sup>59</sup> This he could legally do, for he truly was the "son of God" in the Caesar family tradition.<sup>60</sup>

The adopted process for the deification of humans into a god had for centuries remained within the reserve powers of the Roman Emperor. Roman writer Ovidius (43 BC – AD 18) recorded the deification of Julius Caesar (Divus Julius) after his death in 44 BC.

Augustus and others styled themselves "divine *filius*" or "son of a god" and were hailed as "divine emperors" after their deaths.<sup>61</sup> Their offspring were all "sons of a god", and Mariamne Herod's twins were no exception. Her sons actually had an additional advantage, for a similar tradition existed in the Herod family lineage.

The New Testament writers stated King Herod was "a god and not a man" (Acts 12:22), merely because all kings of Judea were called "God" by the people.<sup>62</sup> There is a solid basis for such an image in the wording of the Gospels and a wealth of narratives exists with which to work.

There are over forty direct references in the New Testament to the twins each being a "son of God" and "born a king" (Matt. 2:2).

Nathanael said to Jesus, for example, "You are the King of Israel" (John 1:49), but there is no record in world history of Jesus ever being a king. Surely King Jesus' existence would have been of immense significance to Israelite history, so why then a blank page? There is an answer.

## Thomas the Twin

The life of Mariamne Herod's twin sons provided the essence of the entire Gospel story. To unravel the "king" story of Jesus ben Panthera, it is first important to clarify the Gospel identity of his twin brother, who was called Judas Thomas or Thomas the Twin in the New Testament.

The name Thomas as applied to Judas is a Graecised form of the Aramaic name Toma. In the Gospel of John,<sup>63</sup> Thomas was also called Didymus—a translation of Toma, meaning "twin". The Hebrew form of the name, Teom,<sup>64</sup> corresponds almost exactly to the English colloquial abbreviation, Tom. In an ancient version of the Syrian New Testament, Thomas is actually called Tommy Didymus (twin twin).

In 1945, the Acts of Thomas was discovered in a collection of thirteen old writings, now called the Nag Hammadi Scrolls, and presented Thomas as Judas Thomas—that is, Judas the Twin.

*The eleventh act introduces Thomas' twin, the other Didymus, as an identical twin who is the lord himself.*<sup>65</sup>

The Acts of Thomas has been preserved with some variations in Greek and in Syriac and bearing the unmistakable signs of its Gnostic origin. The general Church belief is that it was written by a Syrian named Bardesanes (154–222).<sup>66</sup> If the place of its origin was really Edessa, as others for sound reasons supposed,<sup>67</sup> this would lend considerable probability to the statement explicitly made in the Acts that the relics of the apostle Thomas had come from the East.

In more than one place,<sup>68</sup> the Acts of Thomas clearly represents Judas Thomas as the twin brother of the one now called Jesus Christ.

In the reconstruction of the two stories provided in this work, the names of

the main Gospel players have been reinstated to what was understood to be their original state of being.

The Acts of Thomas records an incident where Jesus appeared to a young man who "saw the Lord Jesus in the likeness of the apostle Judas Thomas". Jesus then called: "I am not Judas the Twin who is also Thomas; I am his brother..."

Another narrative from the Acts of Thomas included the phrase, "the one who art mother of twin young ones; come, hidden mother".

During the second and third centuries, the Church writings recorded that Judas Thomas was not only Jesus' blood brother but also his identical twin brother, with the identity of their mother suppressed.

In the Book of Thomas, another ancient writing in the Thomas tradition, Judas Thomas is again explicitly called Jesus' "brother" and "double".<sup>69</sup>

**The premise for the conclusion in this work is that the "ben Panthera" twins were of royal birthright and legitimate contenders to the throne of Palestine and the Emperorship of Rome.**

## What A Suppressed Gospel Said

The Acts of Thomas records that the populace "saw as two beings, one single royal token consisting of two halves" (112:80) and "united their adoration of the two persons of Christ". Not surprisingly, this Gospel along with others was suppressed after the first Christian Council at Nicaea in 325.

Again, in the Acts of Thomas, the issue of Judas the Twin was further clarified by a remarkable statement that referred to the "twin brother of Christ, apostle to the most high and fellow initiate into the hidden word of Christ who does receive his secret sayings". The Church claimed that the "secret sayings" in the Gospel of Thomas were collected and recorded by Judas the Twin from words recited to him by Jesus.<sup>70</sup>

In referring to the Acts of Thomas (*Acta Thomae*) and the Gospel of Thomas, the *Catholic Encyclopaedia* comments:

*His name [Judas the Twin] is the starting point of a considerable apocryphal literature, and there are also certain historical data which suggest that some of this apocryphal material may contain germs of truth.*<sup>71</sup>

The Acts of Thomas "recounts the wanderings and adventures of Didymus Jude Thomas...and his twin brother Jesus"<sup>72</sup> and makes several references to the twin boys being raised in a palace. The Church attributed these words directly to Judas Thomas:

*When I was an infant too young to talk, in my father's Palace reposing in the wealth and luxury of those who nourished me...*<sup>73</sup>

In a section of the Acts of Thomas, sometimes called "In the Country of the Indians", the following words of Judas Thomas appear:

*I remembered that I was a son of Royal parents, and my noble birth asserted its nature.*<sup>74</sup>

A fragment of parchment believed also to be from the Acts of Thomas has Jesus saying to Judas Thomas, "Greetings, Twin, my second messiah". This statement supports the reference to two messiahs documented in one of the Dead Sea Scrolls, "The Book of the Community Rule".

A crucial fact to be remembered when discussing those "lost" works is that the texts in which Judas Thomas appears as Jesus' twin brother were once accepted works of scripture and widely used by the early presbyters in all Western congregations.<sup>75</sup>

Also to be borne in mind is the fact that the Gospel of Thomas and the Acts of Thomas are from the same era as the four canonical Gospels of the New Testament today. This can only mean that during the establishment years of the Christian texts, the idea of a twin was perfectly acceptable, and with the naivety of the times the birth of identical twins was seen as a miraculous and fascinating event.<sup>76</sup>

## Twins in Roman Tradition

The birth of twins was seen by the people of the times as a supernatural occurrence, one of divine origin.

*Once upon a time, in myth, twins signified whatever dualisms a culture entertained: mortal/immortal; good/evil; creation/destruction, what they had.*<sup>77</sup>

A highly respected ancient tradition of the Roman people held that divine twin boys were born to the god Mars and an earthly virgin woman called Ilia. They were Romulus and Remus, the mythical founders of Rome, believed by the people to have been sent to Earth as beautiful human beings and reared as infants in the wild by a she-wolf. They were especially honoured in Rome, where they were worshipped as "The Great Twin Brethren to whom all pray". Romulus slew Remus and subsequently ascended into Heaven and joined the gods. Later, a certain Julius Proculus announced that he had seen Romulus alive, who told him that he had become the god Quirinus. Romulus was then deified as Quirinus.

The story of Romulus and Remus became essentially the myth of Rome in the sense that it embodied the high ideals and values to which they referred over the centuries when they wanted to explain to themselves what it was to be Roman. In this way, the stories of Romulus and Remus may have been deliberate creations, but they could be said to have assumed mythical status over years of repetition and reference.

It shall be shown that the stories of the lives of Mariamne Herod's twin boys later became, because of their Roman father and the royal blood of their mother, a rationalisation of the Romulus and Remus story of the twin founders of Rome.

That Emperor Tiberius carried the genes of twins is noted in the writings of the first-century Roman historian Tacitus, who records the birth of twins to Livilla (d. AD 31) and Drusus (d. AD 23), the son of Emperor Tiberius, as "a rare event [that] so delighted the

Emperor that he did not refrain from boasting before the senators".<sup>78</sup>

That Jesus had a twin brother has been debated for centuries. The great Italian painter Leonardo da Vinci (1452–1519), in his famous interpretation of the Last Supper, appeared to subscribe to this ancient belief with his depiction of one of the disciples (fifth from Jesus' right). He bears an uncanny resemblance to Jesus, not only in physical appearance but also in the matching design and colour of his clothing, complete to the fine detail of the width and shading of the narrow neckband on his costume.

## Michelangelo Reveals a Papal Secret

The supreme sculptor and painter Michelangelo Buonarroti (1475–1564) also avidly preserved the "twin boys" theme in dozens of his famous works of Mary. A Catholic theologian, John Eck (1486–1543), argued against persistent rumours which alleged a secret had been confided to both Leonardo da Vinci and Michelangelo by the Borgia pope<sup>79</sup> and later the de Medici pope, Leo.<sup>80</sup> Pope Leo X was a "pleasure-loving",<sup>81</sup> self-confessed homosexual and one of his partners was Michelangelo.

At some period in their lives, both Michelangelo and Leonardo da Vinci lived in luxurious quarters at the Belvedere<sup>82</sup> on the Vatican Hill and worked on private commissions for both popes. But it was a statement made by Pope Leo X to the Latin Church that strengthened the suspicion that both Leonardo da Vinci and Michelangelo were privy to secret information. Pope Leo X frankly declared, "How well we know what a profitable superstition this fable of Christ has been for us".<sup>83</sup> Truly remarkable

**Again, in the Acts of Thomas, the issue of Judas the Twin was further clarified by a remarkable statement that referred to the "twin brother of Christ, apostle to the most high and fellow initiate into the hidden word of Christ who does receive his secret sayings".**

words, and if Pope Leo X did pass this "fable" on to Leonardo da Vinci and Michelangelo, they may well have preserved the information in their sculptures and paintings.

It seemed strange that both Leonardo da Vinci and Michelangelo constantly portrayed twin boys. The Church reasoned that one of the boys was Jesus Christ and the other John the Baptist. However, these artists clearly created identical twins, and in some cases one appeared slightly unfinished as if to imply that something was being held back. Maybe these men left clues for later generations to unravel.

### **An Intriguing Little Mystery**

The suggestion that Jesus of the Gospels was one of two identical twins was again supported by the discovery of four antique parchments in an old church in the hilltop village of Rennes-le-Château in southern France. There, around 1886, the parish priest Bérenger Saunière uncovered the concealed scrolls while removing the altar stone during restoration. Another discovery of immense importance was also made. While repairing the floor in front of the altar, a flat stone was removed and its underside bore a well-preserved relief of knights on horseback. It is believed to have dated from the time of the building of the church and is known as the *Dalle des Chevaliers*. Saunière used this stone as a step in the garden and it can still be seen in the little museum today.

The scrolls were written in Latin and the first text was a combination of New Testament excerpts from the Gospels of Matthew (12:1–8), Mark (2:23–28) and Luke (6:1–5). All three recorded almost identical information about what was lawful or not lawful to do on the Sabbath. The second scroll provided narratives from the Gospel of John (12:1–11) about the anointing of Jesus Christ. Both writings were said to contain secret, coded messages. The two most valuable parchments were believed to consist of genealogies of Jesus Christ, recorded within a lineage of descent listing the Counts of Rhedae until 1244.<sup>84</sup> It was said that these parchments were of immense importance and contained "incontrovertible proof" that the Crucifixion was a fraud and Jesus was alive as late as AD 45.

The Church showed immense interest in the scrolls, and it was said Saunière later travelled to Paris and revealed their contents to an unknown party. At the same time, he seemed to have been introduced into esoteric circles and returned to his church with a painting of a mediaeval pope, suspected to have been the aforementioned Pope Leo X.

Shortly thereafter, Saunière began to receive a supply of funds that lasted until his death. He spent huge sums of money, much more than his income as a priest allowed.<sup>85</sup> Some of it he used to continue the renovation work. Around this time, Saunière and his housekeeper, Marie Dénarnaud, started to dig in a nearby cemetery at night. The local villagers were so concerned, they lodged an official complaint in writing with their mayor.

Saunière destroyed an ancient tomb and defaced its headstone. For nearly one hundred years it had been the last resting place of a certain Marie de Nègre d'Ables, Dame d'Hautpoul. He was searching for something. Some say he was looking for the mortal

remains of Jesus Christ; others say he was searching for one of the many gold hoards said to be hidden in the region and maybe once belonging to the Knights Templar, the Cathars or the Visigoths, who all once occupied the area.<sup>86</sup>

Whatever secret he knew, he seems to have left behind an intricate and elaborate system of clues, including veiled references to Mary Magdalene. He built a luxurious villa named Béthanie and in 1902 started a four-year construction project to build a tower he called Magdala (after Mary of Magdala?). He also had carved an enigmatic bas-relief of Mary of Magdala and an outsized statue of a horned devil (Pan?) supporting the holy-water font. These items are in the church today. For some reason, he chiselled a cross into a stone pillar and then erected it upside down.<sup>87</sup>

For the restored interior of the church, Saunière commissioned the creation of a series of special decorative wall plaques and some painted statues. Each is characterised by some odd but subtle contradiction of the Church presentation of the birth and death

of Jesus Christ. One decoration portrays a body being carried from a tomb in a nighttime scene with a full moon in the background. The fourteen stations of The Way of the Cross are shown in the opposite direction to other churches and one illustration shows the Magdala Tower in the background. Two statues, one each side of the altar, depict Mary and Joseph each holding an identical baby Jesus (twin boys in the Church, as the suppressed Acts of Thomas records). All statues in the church look sadly at the ground, and one of Mary Magdalene has a skull resting at her feet. A curious painting

shows a Scotsman in a kilt watching the Crucifixion.

In 1916, Saunière commenced negotiations over a construction contract worth FF8,000,000, but ill health intervened. Upon his deathbed, Saunière summoned a neighbouring priest and longtime friend to his side. After a brief discussion with Saunière, the priest left the room ashen-faced, "never to smile again". On 22 January 1917, Saunière died unshriven, at his own request, taking with him the secret of the scrolls which made him rich.<sup>88</sup>

Because a number of priests were involved in the suppression of Saunière's scrolls, conspiracy theorists consider a great Church secret has been concealed. But whatever the secret, what was not secret was the Gospel information on this matter. Judas Thomas was somebody's twin, for the Gospel writers recorded "Thomas, one of the twelve, called the Twin"<sup>89</sup> and that Jesus Christ had a brother called Judas Thomas.<sup>90</sup> Put two and two together, and just what other Gospel evidence does the Church need to supply?

### **Postscript**

For those who wish to research this topic further, check out the writings of a close priesthood friend of Saunière, Henri Boudet, edited in 1886. He was an initiate into the secret mysteries and left clues to the Rennes-le-Château secret in the page numbers of a strange book he wrote towards the end of the 19th century, called *La Vraie Langue Celtique et le Cromlech de Rennes-les-Bains* ("The True Language of the Celts and the Cromlech of Rennes-les-Bains").

**Continued on page 84**







# HIDDEN FROM HISTORY

# THE CANADIAN HOLOCAUST

**Through the Canadian residential school system, the Christian churches along with state authorities, the judiciary, doctors and the police implemented a policy of genocide against the native population.**

**by Rev. Kevin D. Annett,  
MA, MDiv**

© 2001 The Truth Commission  
into Genocide in Canada  
Email: kevinannett@yahoo.ca  
Email: kevin\_annett@hotmail.com  
Website:  
<http://annett55.freewebsites.com/>

*The following is an edited extract from the report, "Hidden From History: The Canadian Holocaust – The Untold Story of the Genocide of Aboriginal Peoples by Church and State in Canada – A Summary of an Ongoing, Independent Inquiry into Canadian Native 'Residential Schools' and their Legacy", by Rev. Kevin D. Annett, MA, MDiv.*

*The report is published by The Truth Commission into Genocide in Canada, a public investigative body continuing the work of previous Tribunals into native residential schools: The Justice in the Valley Coalition's Inquiry into Crimes Against Aboriginal People, convened in Port Alberni, British Columbia, on December 9, 1994, and The International Human Rights Association of American Minorities Tribunal into Canadian Residential Schools, held in Vancouver, BC, from June 12–14, 1998. Editor.*

## FOREWORD

**J**asper Joseph is a sixty-four-year-old native man from Port Hardy, British Columbia. His eyes still fill with tears when he remembers his cousins who were killed with lethal injections by staff at the Nanaimo Indian Hospital in 1944.

*I was just eight, and they'd shipped us down from the Anglican residential school in Alert Bay to the Nanaimo Indian Hospital, the one run by the United Church. They kept me isolated in a tiny room there for more than three years, like I was a lab rat, feeding me these pills, giving me shots that made me sick. Two of my cousins made a big fuss, screaming and fighting back all the time, so the nurses gave them shots, and they both died right away. It was done to silence them. (November 10, 2000)*

Unlike post-war Germans, Canadians have yet to acknowledge, let alone repent from, the genocide that we inflicted on millions of conquered people: the aboriginal men, women and children who were deliberately exterminated by our racially supremacist churches and state.

As early as November 1907, the Canadian press was acknowledging that the death rate within Indian residential schools exceeded 50% (see Appendix, Key Newspaper Articles). And yet the reality of such a massacre has been wiped clean from the public record and consciousness in Canada over the past decades. Small wonder; for that hidden history reveals a system whose aim was to destroy most native people by disease, relocation and outright murder, while "assimilating" a minority of collaborators who were trained to serve the genocidal system.

This history of purposeful genocide implicates every level of government in Canada, the Royal Canadian Mounted Police (RCMP), every mainstream church, large corporations and local police, doctors and judges. The web of complicity in this killing machine was, and remains, so vast that its concealment has required an equally elaborate campaign of cover-up that has been engineered at the highest levels of power in our country; a cover-up that is continuing, especially now that eyewitnesses to murders and atrocities at the church-run native residential "schools" have come forward for the first time.

For it was the residential "schools" that constituted the death camps of the Canadian Holocaust, and within their walls nearly one-half of all aboriginal children sent there by law died, or disappeared, according to the government's own statistics.

These 50,000 victims have vanished, as have their corpses—"like they never existed", according to one survivor. But they did exist. They were innocent children, and they were killed by beatings and torture and after being deliberately exposed to tuberculosis

and other diseases by paid employees of the churches and government, according to a "Final Solution" master plan devised by the Department of Indian Affairs and the Catholic and Protestant churches.

With such official consent for manslaughter emanating from Ottawa, the churches responsible for annihilating natives on the ground felt emboldened and protected enough to declare full-scale war on non-Christian native peoples through the 20th century.

The casualties of that war were not only the 50,000 dead children of the residential schools, but the survivors, whose social condition today has been described by United Nations human rights groups as that of "a colonized people barely on the edge of survival, with all the trappings of a third-world society". (November 12, 1999)

The Holocaust is continuing.

This report is the child of a six-year independent investigation into the hidden history of genocide against aboriginal peoples in Canada. It summarises the testimonies, documents and other evidence proving that Canadian churches, corporations and the government are guilty of intentional genocide, in violation of the United Nations Convention on Genocide, which Canada ratified in 1952 and under which it is bound by international law.

The report is a collaborative effort of nearly 30 people. And yet some of its authors must remain anonymous, particularly its aboriginal contributors, whose lives have been threatened and who have been assaulted, denied jobs and evicted from their homes on Indian reserves because of their involvement in this investigation.

As a former minister in one of the guilty institutions named in our inquiry—the United Church of Canada—I have been fired, blacklisted, threatened and publicly maligned by its officers for my attempts to uncover the story of the deaths of children at that church's Alberni residential school.

Many people have made sacrifices to produce this report, so that the world can learn of the Canadian Holocaust, and to ensure that those responsible for it are brought to justice before the International Criminal Court.

Beginning among native and low-income activists in Port Alberni, British Columbia, in the fall of 1994, this inquiry into crimes against humanity has continued in the face of death threats, assaults and the resources of church and state in Canada.

It is within the power of the reader to honour our sacrifice by sharing this story with others and refusing to participate in the institutions which deliberately killed many thousands of children.

This history of official endorsement of, and collusion in, a century or more of crimes against Canada's first peoples must not discourage us from uncovering the truth and bringing the perpetrators to justice.

It is for this reason that we invite you to remember not only the 50,000 children who died in the residential school death camps, but the silent victims today who suffer in our midst for bread and justice.

(Rev.) Kevin D. Annett  
Secretary

The Truth Commission into Genocide in Canada  
Vancouver, British Columbia, February 1, 2001

## **PART ONE: Summary of Evidence of Intentional Genocide in Canadian Residential Schools**

### **Article II: The intent to destroy, in whole or in part, a national ethnic, racial or religious group; namely, non-Christian aboriginal peoples in Canada**

The foundational purpose behind the more than one hundred Indian residential schools established in Canada by government legislation and administered by Protestant and Catholic churches was the deliberate and persistent eradication of aboriginal people and their culture, and the conversion of any surviving native people to Christianity.

This intent was enunciated in the Gradual Civilization Act of 1857 in Upper Canada, and earlier, church-inspired legislation, which defined aboriginal culture as inferior, stripped native people of citizenship and subordinated them in a separate legal category from non-Indians. This Act served as the basis for the federal Indian Act of 1874, which recapitulated the legal and moral inferiority of aboriginals and established the residential school system. The legal definition of an Indian as "an uncivilized person, destitute of the knowledge of the knowledge of God and of any fixed and clear

belief in religion" (Revised Statutes of British Columbia, 1960) was established by these Acts and continues to the present day.

Then, as now, aboriginals were considered legal and practical non-entities in their own land and, hence, inherently expendable.

This genocidal intent was restated time and again in government legislation, church statements and the correspondence and records of missionaries, Indian agents and residential school officials (see Documentation section). Indeed, it was the very *raison d'être* of the state-sanctioned

Christian invasion of traditional native territories and of the residential school system itself, which was established at the height of European expansionism in the 1880s and persisted until 1984.

By definition, this aim was genocidal, for it planned and carried out the destruction of a religious and ethnic group: all those aboriginal people who would not convert to Christianity and be culturally extinguished. Non-Christian natives were the declared target of the residential schools, which practised wholesale ethnic cleansing under the guise of education.

As well, such "pagans" were the subject of government-funded sterilisation programs administered at church-run hospitals and tuberculosis sanatoriums on Canada's west coast (see Article IId).

According to an eyewitness, Ethel Wilson of Bella Bella, BC, a United Church missionary doctor, George Darby, deliberately sterilised non-Christian Indians between 1928 and 1962 at the R. W. Large Memorial Hospital in Bella Bella. Ms Wilson, who is now deceased, stated in 1998:

*Doctor Darby told me in 1952 that Indian Affairs in Ottawa was paying him for every Indian he sterilised, especially if they weren't church-goers. Hundreds of our women were sterilised by Doctor Darby, just for not going to church. (Testimony of Ethel Wilson to International Human Rights Association of American Minorities [IHRAAM] Tribunal, Vancouver, BC, June 13, 1998)*

According to Christy White, a resident of Bella Bella, records of these government-funded sterilisations at the R. W. Large

**We invite you to remember not only the 50,000 children who died in these residential school death camps, but the silent victims today who suffer in our midst for bread and justice.**

Hospital were deliberately destroyed in 1995, soon after a much-publicised police investigation was to open into residential school atrocities in British Columbia. Ms White stated in 1998:

*I worked at the Bella Bella hospital, and I know that Barb Brown, one of the administrators there, dumped sterilisation records at sea on two occasions. Some of the records were found washed up on the beach south of town. That was just after the cops opened their investigation into the schools, in the spring of 1995. They were covering their tracks. We all knew Ottawa was funding sterilisations, but we were told to keep quiet about it.* (Testimony of Christy White to Kevin Annett, August 12, 1998)

Legislation permitting the sterilisation of any residential school inmate was passed in BC in 1933 and in Alberta in 1928 (see "Sterilization Victims Urged to Come Forward" by Sabrina Whyatt, *Windspeaker*, August 1998). The Sexual Sterilization Act of BC allowed a school principal to permit the sterilisation of any native person under his charge. As their legal guardian, the principal could thus have any native child sterilised. Frequently, these sterilisations occurred to whole groups of native children when they reached puberty, in institutions like the Provincial Training School in Red Deer, Alberta, and the Ponoka Mental Hospital. (Former nurse Pat Taylor to Kevin Annett, January 13, 2000)

Of equal historical significance is the fact that the Canadian federal government passed legislation in 1920, making it mandatory for all native children in British Columbia—the west coast of which was the least Christianised area among aboriginals in Canada—to attend residential schools, despite the fact that the same government had already acknowledged that the death rate due to communicable diseases was much higher in these schools and that, while there, the native children's "constitution is so weakened that they have no vitality to withstand disease". (A. W. Neill, West Coast Indian Agent, to Secretary of Indian Affairs, April 25, 1910)

That is, the Canadian government legally compelled the attendance of the most "pagan" and least assimilated of the native peoples in residential schools at precisely the time when the death rate in these schools had reached their pinnacle—about 40%, according to Indian Affairs officers like Dr Peter Bryce. This fact alone suggests a genocidal intent towards non-Christian aboriginals.

#### **Article II (a): Killing members of the group intended to be destroyed**

That aboriginal people were deliberately killed in the residential schools is confirmed by eyewitness testimonies, government records and statements of Indian agents and tribal elders. It is also strongly suggested by the bare fact that the mortality level in residential schools averaged 40%, with the deaths of more than 50,000 native children across Canada (see Bibliography, inc. the report of Dr Peter Bryce to Department of Indian Affairs Superintendent Duncan Campbell Scott, April 1909).

The fact, as well, that this death rate stayed constant across the years, and within the schools and facilities of every denomination

which ran them—Roman Catholic, United, Presbyterian or Anglican—suggests that common conditions and policies were behind these deaths. For every second child to die in the residential school system eliminates the possibility that these deaths were merely accidental or the actions of a few depraved individuals acting alone without protection.

Yet not only was this system inherently murderous, but it operated under the legal and structural conditions which encouraged, aided and abetted murder and which were designed to conceal these crimes.

The residential schools were structured like concentration camps, on a hierarchical military basis under the absolute control of a principal appointed jointly by church and state, and who was usually a clergyman. This principal was even given legal guardianship rights over all students during the early 1930s by the federal government, at least in west coast residential schools. This action by the government was highly unusual, considering that native people were by law the legal wards of the state, and had been so since the commencement of the Indian Act. And yet such absolute power of the school principal over the lives of abo-

original students was a requirement of any system whose killing of aboriginals had to be disguised and later denied.

The residential schools were constructed behind this deception in such a way that the deaths and atrocities that constitute genocide could be hidden and eventually explained. In the Canadian context, this meant a policy of gradual but deliberate extermination under a protective legal umbrella, administered by "legitimate and trusted" institutions: the mainline churches.

It should be clarified from the outset that the decisions concerning the residential schools, including those which caused the deaths of children and resulting cover-ups, were officially sanctioned by every level of the churches that ran them and the government which created them. Only such sanction could have allowed the deaths to continue as they did—and the perpetrators to feel protected enough to operate with impunity for many years within the system, which they universally did.

#### **• Exposure to Diseases**

In 1909, Dr Peter Bryce of the Ontario Health Department was hired by the Indian Affairs Department in Ottawa to tour the Indian residential schools in western Canada and British Columbia and report on the health conditions there. Bryce's report so scandalised the government and the churches that it was officially buried and only surfaced in 1922 when Bryce—who was forced out of the civil service for the honesty of his report—wrote a book about it, entitled *The Story of a National Crime* (Ottawa, 1922).

In his report, Dr Bryce claimed that Indian children were being systematically and deliberately killed in the residential schools. He cited an average mortality rate of between 35% and 60%, and alleged that staff and church officials were regularly withholding or falsifying records and other evidence of children's deaths.

Further, Dr Bryce claimed that a primary means of killing native children was to deliberately expose them to communicable diseases such as tuberculosis and then deny them any medical

**The residential schools were constructed behind this deception in such a way that the deaths and atrocities that constitute genocide could be hidden and eventually explained.**

care or treatment—a practice actually referred to by top Anglican Church leaders in the *Globe and Mail* on May 29, 1953.

In March 1998, two native eyewitnesses who attended west coast residential schools, William and Mabel Sport of Nanaimo, BC, confirmed Dr Bryce's allegation. Both of them claim to have been deliberately exposed to tuberculosis by staff at both a Catholic and a United Church residential school during the 1940s.

*I was forced to sleep in the same bed with kids who were dying of tuberculosis. That was at the Catholic Christie residential school around 1942. They were trying to kill us off, and it nearly worked. They did the same thing at Protestant Indian schools, three kids to a bed, healthy ones with the dying. (Testimony of Mabel Sport to IHRAAM officers, Port Alberni, BC, March 31, 1998)*

*Reverend Pitts, the Alberni school principal, he forced me and eight other boys to eat this special food out of a different sort of can. It tasted really strange. And then all of us came down with tuberculosis. I was the only one to survive, 'cause my Dad broke into the school one night and got me out of there. All of the rest died from tuberculosis and they were never treated. Just left there to die. And their families were all told they had died of pneumonia. The plan was to kill us off in secret, you know. We all just began dying after eating that food. Two of my best friends were in that group that was poisoned. We were never allowed to speak of it or go into the basement, where other murders happened. It was a death sentence to be sent to the Alberni school. (Testimony of William Sport to IHRAAM officers, Port Alberni, BC, March 31, 1998)*

#### • Homicides

More overt killings of children were a common occurrence in residential schools, according to eyewitnesses.

The latter have described children being beaten and starved to death, thrown from windows, strangled and being kicked or thrown down stairs to their deaths. Such killings occurred in at least eight residential schools in British Columbia alone, run by all three mainline denominations.

Bill Seward of Nanaimo, BC, age 78, states:

*My sister Maggie was thrown from a three-storey window by a nun at the Kuper Island school, and she died. Everything was swept under the rug. No investigation was ever done. We couldn't hire a lawyer at the time, being Indians. So nothing was ever done. (Testimony of Bill Seward, Duncan, BC, August 13, 1998)*

Diane Harris, Community Health Worker for the Chemainus Band Council on Vancouver Island, confirms accounts of the murders.

*We always hear stories of all the kids who were killed at Kuper Island. A graveyard for the babies of the priests and girls was right south of the school until it was dug up by the priests when the school closed in 1973. The nuns would abort babies and sometimes end up killing the mothers. There were a lot of disappearances. My mother, who is 83 now, saw a priest drag a girl down a flight of stairs by her hair and the girl died as a result. Girls were raped and*

*killed, and buried under the floorboards. We asked the local RCMP to exhume that place and search for remains but they've always refused, as recently as 1996. Corporal Sampson even threatened us. That kind of cover-up is the norm. Children were put together with kids sick with TB in the infirmary. That was standard procedure. We've documented thirty-five outright murders in a seven-year period. (Testimony of Diane Harris to the IHRAAM Tribunal, June 13, 1998)*

Evidence exists that active collusion from police, hospital officials, coroners, Indian Agents and even native leaders helped to conceal such murders. Local hospitals, particularly tuberculosis sanatoriums connected to the United and Roman Catholic churches, served as "dumping grounds" for children's bodies and routinely provided false death certificates for murdered students.

In the case of the United Church's Alberni residential school, students who discovered dead bodies of other children faced serious retribution. One such witness, Harry Wilson of Bella Bella, BC, claims that he was expelled from the school, then hospitalised and drugged against his will, after finding the body of a dead girl in May 1967.

Sadly, the two-tiered system of collaborators and victims created among native students at the schools continues to the present,

as some of the state-funded band council officials—themselves former collaborators—appear to have an interest in helping to suppress evidence and silence witnesses who would incriminate not only the murderers but themselves as agents of the white administration.

A majority of the witnesses who have shared their story with the authors and at public tribunals on the west coast have described either seeing a murder or discovering a body at the residential school he or she attended. The body count, even according

to the government's own figures, was enormously high. Where, then, are all these bodies? The deaths of thousands of students are not recorded in any of the school records, Indian Affairs files or other documentation submitted thus far in court cases or academic publications on the residential schools. Some 50,000 corpses have literally and officially gone missing.

The residential school system had to hide not only the evidence of murder but the bodies as well. The presence of secret gravesites of children killed at Catholic and Protestant schools in Sardis, Port Alberni, Kuper Island and Alert Bay has been attested to by numerous witnesses. These secret burial yards also contained the aborted fetuses and even small babies who were the offspring of priests and staff at the schools, according to the same witnesses. One of them, Ethel Wilson of Bella Bella, claims to have seen "rows and rows of tiny skeletons" in the foundations of the former Anglican residential school of St Michael's in Alert Bay when a new school was built there in the 1960s.

*There were several rows of them, all lined up neatly like it was a big cemetery. The skeletons had been found within one of the old walls of St Mike's school. None of them could have been very old, from their size. Now why would so many kids have been buried like that inside a wall, unless someone was trying to hide something? (Testimony of Ethel Wilson to Kevin Annett, Vancouver, BC, August 8, 1998)*

**Such killings occurred in at least eight residential schools in British Columbia alone, run by all three mainline denominations.**

Arnold Sylvester, who, like Dennis Charlie, attended Kuper Island school between 1939 and 1945, corroborates this account. *The priests dug up the secret gravesite in a real hurry around 1972 when the school closed. No one was allowed to watch them dig up those remains. I think it's because that was a specially secret graveyard where the bodies of the pregnant girls were buried. Some of the girls who got pregnant from the priests were actually killed because they threatened to talk. They were sometimes shipped out and sometimes just disappeared. We weren't allowed to talk about this.* (Testimony of Arnold Sylvester to Kevin Annett, Duncan, BC, August 13, 1998)

Local hospitals were also used as a dumping ground for children's bodies, as in the case of the Edmonds boy and his "processing" at St Paul's Hospital after his murder at the Catholic school in North Vancouver. Certain hospitals, however, seem to have been particularly favourite spots for storing corpses.

The Nanaimo Tuberculosis Hospital (called The Indian Hospital) was one such facility. Under the guise of tuberculosis treatment, generations of native children and adults were subjected to medical experiments and sexual sterilisations at the Nanaimo Hospital, according to women who experienced these tortures (see Article IId). But the facility was also a cold storage area for native corpses.

The West Coast General Hospital in Port Alberni not only stored children's bodies from the local United Church residential school; it was also the place where abortions were performed on native girls who were made pregnant at the school by staff and clergy, and where newborn babies were disposed of and possibly killed, according to witnesses like Amy Tallio, who attended the Alberni school during the early 1950s.

Irene Starr of the Hesquait Nation, who attended the Alberni school between 1952 and 1961, confirms this.

*Many girls got pregnant at the Alberni school. The fathers were the staff, teachers, the ones who raped them. We never knew what happened to the babies, but they were always disappearing. The pregnant girls were taken to the Alberni hospital and then came back without their babies. Always. The staff killed those babies to cover their tracks. They were paid by the church and government to be rapists and murderers.* (Testimony of Irene Starr to Kevin Annett, Vancouver, BC, August 23, 1998)

#### **Article II (b): Causing serious bodily or mental harm**

Early in the residential schools era, the Indian Affairs Superintendent, Duncan Campbell Scott, outlined the purpose of the schools thus: "to kill the Indian within the Indian".

Clearly, the genocidal assault on aboriginals was not only physical but spiritual: European culture wished to own the minds and the souls of the native nations, to turn the Indians it hadn't killed into third-class replicas of white people.

Expressing the "virtues" of genocide, Alfred Caldwell, principal of the United Church school in Ahousat on Vancouver Island's west coast, wrote in 1938:

*The problem with the Indians is one of morality and religion. They lack the basic fundamentals of civilised thought and*

*spirit, which explains their child-like nature and behaviour. At our school we strive to turn them into mature Christians who will learn how to behave in the world and surrender their barbaric way of life and their treaty rights which keep them trapped on their land and in a primitive existence. Only then will the Indian problem in our country be solved.* (Rev. A. E. Caldwell to Indian Agent P. D. Ashbridge, Ahousat, BC, Nov 12, 1938)

The fact that this same principal is named by eyewitnesses as the murderer of at least two children—one of them in the same month that he wrote this letter—is no accident, for cultural genocide spills effortlessly over into killing, as the Nazis proved so visibly to the world.

Nevertheless, Caldwell's letter illuminates two vital points for the purpose of this discussion of mental and bodily harm inflicted on native students: (a) the residential schools were a vast project in mind control, and (b) the underlying aim of this "re-programming" of native children was to force aboriginals off their ancestral lands in order to allow whites access to them.

To quote Alberni survivor Harriett Nahanee:

**The residential schools became a safe haven—one survivor calls it a "free fire zone"—for pedophiles, murderers and brutal doctors needing live test subjects for drug testing or genetic and cancer research.**

*They were always pitting us against each other, getting us to fight and molest one another. It was all designed to split us up and brainwash us so that we would forget that we were Keepers of the Land. The Creator gave our people the job of protecting the land, the fish, the forests. That was our purpose for being alive. But the whites wanted it all, and the residential schools were the way they got it. And it worked.*

*We've forgotten our sacred task, and now the whites have*

*most of the land and have taken all the fish and the trees. Most of us are in poverty, addictions, family violence. And it all started in the schools, where we were brainwashed to hate our own culture and to hate ourselves so that we would lose everything. That's why I say that the genocide is still going on.* (Testimony of Harriett Nahanee to Kevin Annett, North Vancouver, BC, December 11, 1995)

It was only after the assumption of guardianship powers by the west coast school principals, between 1933 and 1941, that the first evidence of organised pedophile networks in those residential schools emerges. For such a regime was legally and morally free to do whatever it wanted to its captive native students.

The residential schools became a safe haven—one survivor calls it a "free fire zone"—for pedophiles, murderers and brutal doctors needing live test subjects for drug testing or genetic and cancer research.

Particular schools, such as the Catholic one at Kuper Island and the United Church's Alberni school, became special centres where extermination techniques were practised with impunity on native children from all over the province, alongside the usual routine of beatings, rapes and farming out of children to influential pedophiles.

Much of the overt mental and bodily harm done to native students was designed to break down traditional tribal loyalties along kinship lines by pitting children against each other and cutting

them off from their natural bonds. Boys and girls were strictly segregated in separate dormitories and could never meet.

One survivor describes never seeing her little brother for years, even though he was in the same building at the Alert Bay Anglican school. And when children at the schools broke into each other's dormitories and older boys and girls were caught exchanging intimacies, the most severe punishments were universally applied. According to a female survivor who attended the Alberni school in 1959:

*They used the gauntlet on a boy and girl who were caught together kissing. The two of them had to crawl naked down a line of other students, and we beat them with sticks and whips provided by the principal. The girl was beaten so badly she died from kidney failure. That gave us all a good lesson: if you tried having normal feelings for someone, you'd get killed for it. So we quickly learned never to love or trust anyone, just do what we were told to do. (Testimony of anonymous woman from the Pacheedat Nation, Port Renfrew, BC, October 12, 1996)*

According to Harriett Nahanee:

*The residential schools created two kinds of Indians: slaves and sell-outs. And the sellouts are still in charge. The rest of us do what we're told. The band council chiefs have been telling everyone on our reserve not to talk to the Tribunal and have been threatening to cut our benefits if we do. (Harriett Nahanee to Kevin Annett, June 12, 1998)*

The nature of that system of torture was not haphazard. For example, the regular use of electric shocks on children who spoke their language or were "disobedient" was a widespread phenomenon in residential schools of every denomination across Canada. This was not a random but an institutionalised device.

Specially constructed torture chambers with permanent electric chairs, often operated by medical personnel, existed at the Alberni and Kuper Island schools in British Columbia, at the Spanish Catholic school in Ontario, and in isolated hospital facilities run by the churches and Department of Indian Affairs in northern Quebec, Vancouver Island and rural Alberta, according to eyewitnesses.

Mary Anne Nakogee-Davis of Thunder Bay, Ontario, was tortured in an electric chair by nuns at the Catholic Spanish residential school in 1963 when she was eight years old. She states:

*The nuns used it as a weapon. It was done on me on more than one occasion. They would strap your arms to the metal arm rests, and it would jolt you and go through your system. I don't know what I did that was bad enough to have that done to me. (From *The London Free Press*, London, Ontario, October 22, 1996)*

Such torture also occurred at facilities operated by the churches with Department of Indian Affairs money, similar to the sterilisation programs identified at the W. R. Large Memorial Hospital in Bella Bella and the Nanaimo Indian Hospital.

Frank Martin, a Carrier native from northern BC, describes his forcible confinement and use in experiments at the Brannen Lake Reform School near Nanaimo in 1963 and 1964:

*I was kidnapped from my village when I was nine and sent off to the Brannen Lake school in Nanaimo. A local doctor gave me a shot and I woke up in a small cell, maybe ten feet by twelve. I was kept in there like an animal for fourteen months. They brought me out every morning and gave me electric shocks to my head until I passed out. Then in the afternoon I'd go for these X-rays and they'd expose me to them for minutes on end. They never told me why they were doing it. But I got lung cancer when I was eighteen and I've never smoked. (Videotaped testimony of Frank Martin to Eva Lyman and Kevin Annett, Vancouver, July 16, 1998)*

Such quack experimentation combined with brutal sadism characterised these publicly funded facilities, especially the notorious Nanaimo Indian Hospital. David Martin of Powell River, BC, was taken to this hospital in 1958 at the age of five and used in experiments attested to by Joan Morris, Harry Wilson and other witnesses quoted in this report. According to David:

*I was told I had tuberculosis, but I was completely healthy; no symptoms of TB at all. So they sent me to Nanaimo Indian Hospital and strapped me down in a bed there for more than six months. The doctors gave me shots every day that made me feel really sick, and made my skin all red and itchy. I heard the screams of other Indian kids who were locked away in isolation rooms. We were never allowed in there to see them. Nobody ever told me what they were doing to all of us in there. (David Martin to Kevin Annett, Vancouver, November 12, 2000)*

**Former employees of the federal government have confirmed that the use of "inmates" of residential schools was authorised for government-run medical experiments through a joint agreement with the churches which ran the schools.**

A recurring and regular torture at the residential schools themselves was operating on children's teeth without using any form of anaesthesia or painkiller. Two separate victims of this torture at the Alberni school describe being subjected to it by different dentists, decades apart. Harriett Nahanee was brutalised in that manner in 1946, while Dennis Tallio was "worked on by a sick old guy who never gave me painkillers" at the same school in 1965.

Dr Josef Mengele is reputed by survivors of his experiments to have worked out of Cornell University in New York, Bristol Labs in Syracuse, New York, and Upjohn Corporation and Bayer laboratories in Ontario. Mengele and his Canadian researchers, like the notorious Montreal psychiatrist Ewen Cameron, used prisoners, mental patients and native children from reserves and residential schools in their efforts to erase and reshape human memory and personality, using drugs, electric shocks and trauma-inducing methods identical to those employed for years in the residential schools.

Former employees of the federal government have confirmed that the use of "inmates" of residential schools was authorised for government-run medical experiments through a joint agreement with the churches which ran the schools.

According to a former Indian Affairs official:

*A sort of gentlemen's agreement was in place for many years: the churches provided the kids from their residential schools to us, and we got the Mounties to deliver them to whoever needed a fresh batch of test subjects: usually doctors,*

**Continued on page 85**







# SUPER-MICROSCOPES AND THE MYSTERIES OF MORPHOGENESIS

*Super-microscopes able to detect the morphogenesis of the tiniest micro-organisms offer a bright future for biology, despite their history of suppression by the medical authorities.*

by Greg Fredericks, ND, NMD

© 2001

Director  
Nu-Look Biologics  
Perth, Western Australia  
Email:  
Nu-LookBiologics@bigpond.com

## MONOMORPHISM AND PLEOMORPHISM

In the early 20th century, fierce debates in biology took place between followers of *monomorphism* and those of *pleomorphism*—the monomorphists believing that bacteria reproduce by single division, and the pleomorphists believing that bacteria could change into complex forms and transform through complex life cycles. The debates raged for decades and were finally won by the monomorphist schools. Their principles are firmly planted in mainstream biology today.

In an excellent research paper, Milton Wainwright describes how Virchow, Cohn and Koch proposed that bacteria divide transversely by binary fission to produce two new cells which eventually achieve the same size and morphology as the original. Exceptions to this rule are accepted in certain so-called higher bacteria including some actinomycetes. In the other camp, Almquist, Bergstrand, Hort, Lohnis, Mellon and Enderlein led the pleomorphists. Some were more extreme in their views than others. However, Ferdinand Cohn, known as a monomorphist biologist, published evidence in support of extreme pleomorphism.

According to Wainwright, by the early 1930s some extreme voices of pleomorphism, including Wade and Manalang as well as Swedish microbiologist Bergstrand, stated that bacteria had a fungal phase. Monomorphists had a field day criticising the apparently absurd claims made by the pleomorphists. Most notable of the continuing criticisms is a claim that pleomorphists used poor technique and that their delusions were a result of contamination; they further arranged these contaminants into convenient life cycles.

Henrici in particular objected to the criticism that extreme pleomorphism resulted from contamination. Instead, his opinion was that "anyone who will patiently study with the microscope his own cultures which he knows to be pure can quickly confirm the general observation that rod forms may appear in cultures of cocci, spherical forms in cultures of bacilli, lateral buds and branches and internal globular bodies". Today, this thesis is generally adopted by notable homoeopathic doctors such as Harvey Biegelsen, Scott Moyer, Ronald Ulman and others.

While many microbiologists hold that pleomorphism is a result of poor technique, a new description known as *oligomorphism* has been created (Frobisher). This describes the limited pleomorphic changes that can arise from meticulously produced, pure cultures.

The debate continues but the tide has turned towards the pleomorphist school, and dark-field microscopy is the main instrument of the new biology.

Conventional cellular biology has yet to acknowledge that micro-organisms, especially viruses, change form due to their environment or milieu. What is becoming increasingly clear is that new diseases and variations such as VRE (vancomycin-resistant enterococcus) have developed. Is it possible that biology has been diverted down the wrong road, as predicted by Enderlein?

## THE FATHERS OF PLEOMORPHISM

### • Antoine Béchamp (1816–1908)

Béchamp, a man virtually unknown today, was the most important microbiologist of the 19th and early 20th centuries. A clever chemist and microscopist, he made many important biological discoveries for which others took the credit. His main discovery was *microzymas*: autonomous entities found in plants and animals. He further discovered that these are integral agents in decomposition and in pathological processes, and he believed

that these microzymas could evolve into bacterial forms. Béchamp showed that the cell must not be regarded as the smallest unit of life.

During his career as a professor at the University of Toulouse, he advanced his microzyma theory, which postulates that all bacteria have a common ancestor which is present throughout nature. Its pathogenicity is determined by its environment or terrain. The microzymas themselves are not the primary cause of disease, but are an integral contributor.

Béchamp's concepts were considered too complex, and they related more to degenerative diseases than the infectious diseases that were the concern of the era. Many of his concepts and discoveries were plagiarised by Louis Pasteur, who overshadowed Béchamp and attempted to discredit him. Béchamp was a quiet man and was no match for the boisterous grandstanding of Pasteur.

Béchamp's work, *Les Microzymas* (1881), stands as the foundation for all pleomorphic research conducted today. Microzymas have been rediscovered many times since. Enderlein's *endobionts*, Reich's *bions* as well as Naessens's *somatids* are all examples of the rediscovery of Béchamp's forgotten concepts.

Béchamp's last work, *The Third Element of the Blood*, is probably his most famous. In this book he refers to his ongoing confrontation with Pasteur. His problems with Pasteur were once again the theme in Ethel Douglas Hume's book, *Pasteur Exposed* (1923). In it, she reveals in detail Pasteur's plagiarisms and his distortion of Béchamp's concepts. This was later supported by R. B. Pearson in his book, *Pasteur: Plagiarist, Impostor* (1942).

Most of the following scientists and microbiologists ended up as victims of political expediency and dogma. The authorities in power persecuted some for their beliefs. Béchamp, on the other hand, received many prestigious awards and appointments, including Master of Pharmacy, Doctor of Science, Doctor of Medicine, Professor of Medical Chemistry and Pharmacy at the Faculty of Medicine at Montpellier, Fellow and Professor of Physics and Toxicology at the Higher School of Pharmacy at Strasbourg and Professor of Chemistry at Strasbourg, Member of the Imperial Academy of Medicine of France and the Society of Pharmacy of Paris, the French Legion of Honour and Officer of Public Instruction.

#### • Günther Enderlein (1872–1968)

Günther Enderlein was a bacteriologist/zoologist who practised and taught in Germany as a doctor, a homoeopath and a professor. Widely known for his discoveries in live blood research, he developed darkfield blood analysis, and produced his most significant work, *Bacteria Cyclogeny*, in 1933 [the German-language first edition was published in 1916].

His discovery of the endobiont led him to develop specific isopathic/homoeopathic vaccines which are still in use today. The Sanum remedies have Enderlein's original formulations as well as those developed since his time. They are called vaccines because they decrease in potency with more dilutions, rather than increase in potency with more dilutions as in homoeopathic formulations.

He found that when the microflora in the terrain of the blood were in harmony, no pathogenesis or ill health could prevail;

whereas when changes occurred to disrupt the terrain and the symbiotic endobiont, corresponding health changes also occurred.

Enderlein observed the tiny motile particles in darkfield and called them *protits*. Like Béchamp's microzymas, these protits he considered responsible for stability of health or the rise in pathogenic processes.

Enderlein also developed key concepts of how pathogenic processes could develop due to changes in the blood terrain, pH being a main factor. For as the pH changes, so does the endobiont (in the form of protits). As the pH rises, they start to grow larger and accumulate protein reserves as an adaptation response and defence mechanism. Toxins, chemicals and emotions can change biochemical reactions in the body and thus affect the terrain and the endobiont which lives symbiotically. The result can be the formation of bacterial forms and other pathogenic morphologies as the influence on the terrain increases.

Dr Professor Enderlein's concepts have not been widely accepted by mainstream haematology. His concepts are complicated and the terms he uses to describe morphologies are his own jargon. Thus the language does not conform, nor do his concepts.

Enderlein found the most advanced forms of the endobiont in the tissues of corpses. These were advanced fungal forms, found to a lesser degree in patients with degenerative diseases.

**During his career as a professor at the University of Toulouse, Béchamp advanced his microzyma theory, which postulates that all bacteria have a common ancestor which is present throughout nature.**

#### • Royal Raymond Rife, Jr (1888–1971)

Royal Raymond Rife was an inventor, scientist and biochemist who had endless skills in manufacturing his own devices, including microscopes [see articles in NEXUS 2/16, 5/02, 5/03]. There are five known Rife microscopes and many copies in existence. His most famous microscope was his third model, the Universal Microscope (1933), with a magnification of 60,000x and a resolution of 31,000x.

He developed these "virus microscopes" as a response to his work in tuberculosis during the 1920s. He became aware of small bacterial/viral-like particles showing "Brownian movement" or motility below the level of most bacteria.

Dr Rife was well known during his time for his work with cancer treatments, including the famous beam ray device. Through his use of the microscope, he learned that each virus or bacterium had its own resonating frequency. For instance, he said that the cancer organism elicited a distinctive purple-red emanation, and he called this particular entity *Bacillus X* or *BX*. He repeated experiments over 400 times, proving that the BX would induce cancerous tumours every time. Through his microscope, Rife was able to see the BX virus being destroyed by his frequency wave device. He further discovered that other organisms responsible for disease had a *mortal oscillatory rate* (MOR). He developed many instruments for treating diseases using resonant frequencies.

Rife believed in the conversion of many types of bacterial species from one form to another. He demonstrated this through environmental and nutrient manipulation, but became caught in a war between two schools of bacteriology: the filtrationist and the antifiltrationist.

Rife was praised for his amazing discoveries and contributions to science, but he was persecuted for his cancer cures by the American Medical Association (AMA). His main supporter, Dr

Milbank Johnson, was found poisoned to death after being hospitalised hours before a press conference to announce the results of a test study conducted by a University of San Francisco research group.

In 1934, Rife and his team treated 16 terminally ill cancer patients. He used his ray device on each patient for three minutes per day and cured them all within three months. But the Californian Medical Society opposed Rife's unorthodox research and treatments and severely disciplined any doctor who used his techniques, machines, microscopes and postulates.

Rife believed that there are approximately only 10 basic microbes. Variations or pleomorphic changes of these basic forms could result from toxicity or pH changes in the medium in which they live.

While most of the work and some microscopes were destroyed by the AMA under the direction of Dr Morris Fishbein, some of Dr Rife's work and microscopes are still in existence, taken to Mexico by his partner, the late John Crane, after Rife's death in 1974.

#### • Wilhelm Reich (1897–1957)

This Austrian psychiatrist/biophysicist was a member of Sigmund Freud's inner circle in Vienna. Wilhelm Reich later broke with Freud and moved to Scandinavia and then Germany, where he was ostracised by Hitler's Nazis after referring to them as sexual deviants. He later fled to America to avoid being persecuted.

Dr Reich's earlier work in the 1930s and 1940s is most pertinent to our studies, especially *The Bion Experiments* (1939) and *The Cancer Biopathy* (1948). While investigating the bioenergetic influences of human emotion and sexuality, Reich discovered a particle

in the blood, which he called a *bion*. He believed that this particle was at the border between the world of living and nonliving matter. Reich found that these particles had the ability to develop into micro-organisms such as protozoa. These experiments have been duplicated by others since Reich in investigations of the origin of life. Reich was the first to develop autoclaving techniques to separate bions from other particles, including chylomicrons. He found bions could withstand temperatures exceeding 1500°C.

Reich found that bions from healthy sources emitted a blue colour (the colour of orgone) and showed highly energetic movement. The bions from unhealthy terrain or weak materials developed into smaller, lancet-shaped dark forms of a more toxic nature, which he called T-bacilli. These T-bacilli were found in cancer patients.

His findings were diametrically opposed to Pasteur's germ theory and reveal similar correlations with earlier work by Béchamp and Enderlein. He had similar findings to Rife, who was doing work in America at about the same time. His autoclaving techniques were later adapted by Naessens (for separating somatids from chylomicrons), while other methods have been used by Dr Kurt Donsbach (protozoa demonstrations).

Later, Dr Reich was persecuted by the FDA for conducting "quack cancer treatments". On 5 June 1956, FDA officials raided his home and laboratory in Rangeley, Maine, destroying his instruments and burning all his books, journals and lifelong research (six tons in total). Reich died in jail on 3 November

1957 from cardiovascular failure. His work in bion research is carried on today by James DeMeo, PhD, at the Orgone Biophysical Research Laboratory; see [www.orgonelab.org](http://www.orgonelab.org).

#### • Gaston Naessens (born 1924)

Born on 26 March 1924 in Roubaix, France, Naessens received his education in biology, chemistry and physics at the University of Lille and from the Union Nationale Scientifique Française, which was a haven for displaced students during World War II. He became a freelance researcher early in his career and in the post-war years he developed novel anticancer products such as GN24, which was sold in Swiss pharmacies in the late 1940s, apparently with good results.

His next development was a serum made from extracting antibodies from racehorses after injecting them with cancer cell cultures. This serum, called Anablast, was developed in his laboratory in Corsica. It proved to have even better anticancer properties than GN24 against tumours as well as leukaemia.

Through his development of anticancer treatments, Naessens became a target for persecution by medical authorities. He has faced many court cases throughout his career, but he has won all of his court battles and has been exonerated every time.

Naessens's contribution to darkfield microscopy has also been remarkable. To assist in his research, he developed a special microscope called the Somatoscope. This microscope has routinely produced a resolution of 150 angstroms, allowing incredible clarity at high magnifications.

In 1971, Naessens came under the protective wing of a philanthropist and was funded to develop new cancer cures. He went on to develop a completely different treatment from

Anablast, which he named 714X. This 714X treatment is still available and is used throughout the world by medical doctors, who can obtain the compound through direct ordering.

Naessens is the head of the International Academy of Somatidian Orthobiology, 5270 Mills Street, Rock Forest, Quebec, Canada J1N 3B6, tel +1 (819) 564 7883, fax +1 (819) 564 4668, website [www.cerbe.com](http://www.cerbe.com). Lynn Acken is the contact for books, tapes, courses and the diachromatic condenser as well as 714X. [For additional information on Gaston Naessens and his work, see NEXUS 2/18, 2/23 and 7/02.]

#### THE SUPER-MICROSCOPES

The 20th century has witnessed the development of microscopes far exceeding the normal restrictions of magnification.

#### • Rife's #3 Universal, #4 and #5

Royal Raymond Rife's microscopes, particularly #3 Universal (1933) and #4 and #5, the last models (1938), were classified as super-microscopes, with a magnification of 60,000x and resolution of 31,000x. It is believed that Rife managed to combine fluorescence, polarisation, darkfield and interference microscopy.

However, very little evidence remains concerning the photomicroscopy produced by these microscopes. John Crane, who had the #3 and #4, did show negatives to one investigator, Hubbard; these showed features 10 nanometres in size (200 nm is the normal limit of resolution). The Rife scopes used normal A.0 and

**Reich discovered a particle in the blood which he called a *bion*. He found that these particles had the ability to develop into micro-organisms such as protozoa.**

Leitz objectives and 40x eyepieces. Investigators who dismantled or attempted to operate these scopes refer to their complexity. The scopes had worm gears and screws to adjust, raise or lower everything, all beautifully machined. According to John Crane, Rife used light to stain objects because the chemicals normally used were either lethal to specimens or molecularly too large.

#### • The Nemescope

Another super-microscope, known as the Nemescope, was the invention of a brain surgeon, Elmer P. Nemes, in the early 1950s. Many pictures were produced from this microscope, which projected images on a 12 foot by 12 foot screen.

The Nemescope produced two sources of energy—one being the frequency of the specimen, the second being a slightly different frequency. The method produced an excitatory response in the atoms and a self-illumination of coloured light frequencies. It was reported to far exceed the 16,000x magnification of the electron microscopes of the day. According to reports, the scope could keep its resolution up to 5,000,000x magnification and project the images onto a screen using radiation beams, a quartz condenser, frequency coils, filters and radioactive emitters.

According to Betty Lee Morales of Topanga, California, clandestine research on the Nemescope was orchestrated by Congressman Craig Sheperd of San Bernardino, California, who arranged for major funds appropriation for the project.

Following a series of successful experiments, the Nemescope was stolen from the Bryn Camera Shop on Melrose Avenue in 1957. It was in the shop, having an electric field finder installed at the time of the theft. The Nemescope was traced to New York, where it vanished.

In 1959, a complete construction guide was produced with the hope that someone would one day duplicate the technology. The guide is free. Contact Jerry at +1 (214) 324 8781 or Ron at +1 (214) 242 9346.

#### • The Somatoscope

Designed by German artisans from the Leitz Co. in Wetzlar in the 1970s and used by Gaston Naessens, the Somatoscope is worthy of the super-microscope classification. It was Barbie-Bernard at Turenne, near Paris, who did the construction of the Somatoscope. Naessens developed a method to condense ultraviolet and incandescent light into his diachromatic condenser to produce nuauges at 30,000x with amazing clarity with a resolution of 150 angstroms.

Funded by a benefactor, the late David Stewart of the Macdonald-Stewart Foundation, Naessens has been able to operate his laboratory and conduct studies in pleomorphism. The Somatoscope can be seen at the yearly two-day course held in July in Forrestfield, Quebec.

#### • The Ergonom 400

Another notable German-designed super-microscope was built by the scientist Kurt Olbrich and was known as the Ergonom 400, the result of 30 years of research. With a magnification of 25,000x, it attempts to rival the capabilities of the Somatoscope.

The Ergonom 400 is used by the German health practitioner Bernard Muschlein, who has given demonstrations throughout

Europe and America. Videos have been produced, demonstrating the development of pleomorphic forms.

Olbrich has produced seven known copies of the Ergonom 400 for researchers in the UK, Europe and Japan. It has a resolution of 1,000 angstroms. Bernard Muschlein, who does research on AIDS and cancer, claims the "AIDS virus transforms full-spectrum white light into red, while healthy erythrocytes transform white light to yellow".

#### • Lightwave Projector

The July 1990 issue of popular science magazine called *SuperScopes* refers to an extraordinary microscope engineered at Cornell University, USA. Instead of normal lenses, the microscope projects wavelengths of visible light through apertures with a 400-angstrom resolution at 25,000x magnification. The Microbiology Department of Cornell, under Professor Michael Isaacson, has also made this microscope available to Israel.

#### MISCONCEPTIONS

With every orifice of the body containing many varieties of bacteria and the blood being a "perfect culture medium", what leap in faith is necessary to believe that the blood is not sterile? Anyone who has used a darkfield microscope for blood analysis can verify that the blood is a virtual playground for various blood flora (Scott Moyer, *Examination in Darkfield*, video, 1996).

The adversarial mindset of modern medicine has failed. Attempting to kill all microbes and viruses is futile. Who could have imagined that Ferdinand Cohn's (1870) belief that each microbe has a single specific growth and reproductive form would be still at the forefront of biological doctrine today, and that William Harvey's (1651) belief that the cell is the smallest biological unit capable of cyclic reproduction could still prevail?

These misconceptions are the basis of most current medical doctrine, which has been further influenced by Louis Pasteur's belief that the blood of humans is sterile. Pathology under his system can only happen due to an external pathological influence invading the body. Pasteur's belief system is the template from which modern pharmaceutical research and development continues to operate. The notion of a drug or vaccine for each pathological disturbance has undoubtedly created huge economic power.

As quoted in Dr Maria Bleker's book, *Blood Examination in Darkfield according to Prof. Dr Günther Enderlein* (1993) the statement by Max Planck (1858-1947), German physicist and Nobel Prize winner, deserves repeating: "In science it takes sixty, not thirty years for a new and revolutionary idea to establish itself. Not only must the old professors die off, so must their students."

Let us hope that the oppositionist forces in medicine will open up to new, alternative medical diagnoses and treatments for the advancement of medical science and the benefit of all mankind in the new millennium.

#### Editor's Note:

This article is extracted/edited from chapters 1, 2, 3 and 6 of Greg Fredericks's book, *Darkfield Warriors: Your Definitive Guide to the World of Darkfield Live Blood Microscopy* (Nu-Look Biologics, Australia, 2001, ISBN 0-9579826-0-7).

**The adversarial mindset of modern medicine has failed. Attempting to kill all microbes and viruses is futile.**







## A HIGH-EFFICIENCY FUEL IMPLOSION SYSTEM (and its Persecuted Inventor)

by Allen Caggiano © 2001

### Trial and Error, then Success

In the early 1970s I owned and operated a company called Debal Heating and Air Conditioning in Brockton, Massachusetts, USA. This was about the time that we had that phony gasoline shortage. Each morning, I and 12 employees would sit in the gas line with six trucks to get a mere five gallons of gasoline.

As I sat in that gasoline line, day after day, I started to think: "There must be a better way. If they have the technology to put a man on the Moon, they must have the technology to get much better gas mileage."

I read everything that I could get my hands on about this technology. It wasn't long before I built my first fuel vaporisation system.

Well, sad to say, it didn't work. It made plenty of vapours and exploded like a bomb. Over 70 per cent of my body received third-degree burns. I spent 69 days in intensive care, kissing death several times. Don't worry—all the bugs are worked out now.

October 15, 1983 was the birth of my fuel implosion vaporisation system. At this time I owned and operated a company in Brockton called Weatherall Energy Research and Development. I had just finished building a commercial, high-efficiency air conditioning evaporating coil. I poured one gallon of gasoline into one end to flush it out, and, to my surprise, massive fumes discharged from the other end—and all I got back was less than one cup of gasoline.

I started brainstorming. I miniaturised the air conditioning evaporator coil and installed it in a 1973 Dodge station wagon with a 318 engine. By early 1986 we had worked out all the shortcomings and bugs and had a working prototype that gave between 111 to 113 mpg.

We placed ads in the *Brockton Enterprise* and *Boston Globe*, seeking people to beta-test our fuel implosion system. It wasn't long before I got a call from a California corporation wanting exclusive rights to our invention. My attorney checked them out. They were a subsidiary of several other corporations, finally all owned by an oil company. I declined their offer.

**THIS CAR GETS OVER 100 MPG AND DOESN'T POLLUTE THE AIR.**

**THE BIG BOYS ARE TRYING TO MAKE ME AND THIS CAR DISAPPEAR. HELP ME.**

### FBI Threats and Surveillance

Shortly thereafter, all my troubles started. First came two men, showing IDs, saying that they were from the FBI and that I was violating federal laws by altering carburetion systems and that if convicted I could get 20 years in a federal prison. I called my attorney and told him what happened. My attorney informed me that I wasn't in any violation of any federal laws.

If I'd been smart, I should have stopped there (but I am not too smart). For about the next two weeks I would receive every day in the mail, in a plain envelope, 8 x 10 close-up photos of my wife in the supermarket and church and my children getting on and off the school bus and in the playground at school (just pictures only). In addition, we would get all kinds of weird calls, mostly after 2 am. My wife couldn't take it any more; she filed for divorce and left me.

A few days later, my attorney showed up at my office, looking white as a ghost. He had all my legal files and records with him and placed them on my desk and said that he could no longer represent me in any legal matters. I asked why. All he would say was "Wake up" and that I did not understand. He had been my personal friend and attorney for over 16 years.

### A Police Drugs Set-up

When my wife divorced me, my attorney abandoned me, what else could happen? I thought that nothing, nobody could stop me now—so on with my fuel implosion system. Boy, was I wrong! All hell opened up and swallowed me alive.

I am a very light drinker. If I drank six cans of beer a year, I did a lot of drinking. I never did drugs or was around anybody that did. But on July 4, 1986, the Chief of the Brockton Police, Richard Sprawls, with a bunch of other Brockton police, raided my Tremont Street, Brockton, home and arrested me for trafficking of cocaine. My bail was set at \$500,000.

I was lucky that I had a friend, Lt Jim Sullivan of the Brockton Police Department. He showed up at my bail hearing and said something to the Judge and my bail was reduced to \$500. Was somebody trying to tell me something?

### Another Raid and a Daring Escape

Oh well, back to work. I built two more fuel implosion systems and installed them in a 1973 Oldsmobile Cutlass and a 1966 Mustang. I painted my 1973 Dodge station wagon bright yellow with big red letters all over it, saying:

**THIS CAR GETS OVER 100 MPG AND DOESN'T POLLUTE THE AIR. THE BIG BOYS ARE TRYING TO MAKE ME AND THIS CAR DISAPPEAR. HELP ME.**

I only got to drive my yellow wagon for three days.

On November 24, 1986, Brockton Chief of Police Richard Sprawls and other members of the Brockton Police Department raided my Tremont Street home and seized two shotguns, a 12-gauge and a 20-gauge. Both were legally registered to me; I used to use them for skeet shooting. I was arrested and charged with trafficking of cocaine again.

My bail was revoked and I was placed in maximum security in the Plymouth house of correction. I was sentenced to 15 years for the July 1986 trafficking of cocaine and was now waiting for the second trial for the November arrest.

I knew where I could get some solid evidence that would clear me, but I didn't know who to trust anymore.

So I escaped from maximum security.

Boy, I was lucky, as they had over 240 law enforcement officers searching for me with guns, dogs, helicopters, etc. I ran like a jackrabbit through the woods. My advantage was that the woods were my old hunting grounds.

I went and got my solid evidence and gave it to the right person and surrendered the same day.

Two days later, Brockton's Chief of Police was arrested for stealing cocaine from the police evidence locker. He was sentenced to two years in prison.

Remember the cocaine that Chief Richard Sprawls said he found at my home in July and November 1986? Now I know where it came from: the police evidence locker. And it fell out of Chief Sprawls's pocket onto the floor in my home, where another Brockton police officer found it.

Well, the Massachusetts Supreme Court of Appeals overturned my cocaine trafficking conviction on the grounds of tainted evidence and an illegal search and seizure.

## The Feds and False Charges

Freedom and home, here I come! Wrong again.

Here come the Feds... They had a warrant for my arrest for violating a new gun law that was passed on November 24, 1986. That was just 10 days after my arrest of November 14, 1986.

Remember the Brockton Police seized my two shotguns? Guess what? I had the privilege of being the first person in

you'd ever been convicted of a felony. I checked the "No" box because I had never been convicted of a felony, just a misdemeanor.

Well, the Feds said that under federal law my misdemeanor was a felony, therefore I was guilty on two counts of perjury. They gave me five years on each count.

Next, I got five years for being a convicted felon in possession of a firearm.

Now I had been sentenced to a total of 15 years in federal prison without parole.

I was still sitting in the courtroom after a week of the trial, and my attorney said that the US attorney was trying me under the second part of the new law. My attorney said the trial would be short; wouldn't last more than 10 minutes. There was no way that I could be found guilty.

Well, it went like this: I was convicted as a felon in possession of a firearm; I was convicted of perjury; and I was convicted on a second count of perjury.

Bingo! I hit the jackpot! USC18922G-E1 states that if you have three prior felony convictions and have possession of a firearm, then you are an armed courier criminal and this carries a minimum mandatory sentence of 15 years without parole.

Now I had a total of 30 years in federal prison without parole.

## A Patent from Prison, then Parole

Well, the Feds have me tucked away for 30 years where I cannot cause any more trouble with my fuel implosion system. Wrong, wrong, wrong!

I met a lot of powerful people in the federal prison with powerful connections on the outside—among them Kenny D., whose son is a patent attorney for a large patent law firm and who did our US Patent #5,782,225 while I sat in the safety of the federal prison system.

Remember the Feds sentenced me to 30 years without parole? Well, on September 13, 1997 (Friday the thirteenth, my lucky

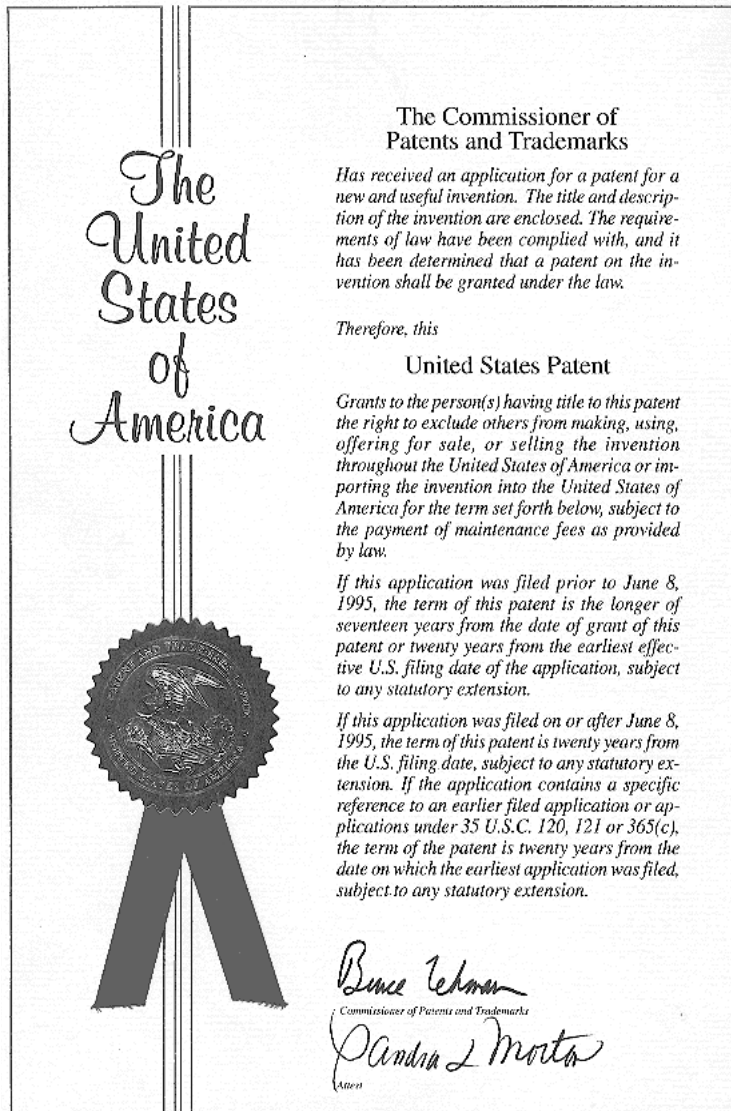

Massachusetts and the third person in the United States to be tried, prosecuted and sentenced under this new law, USC 16921G and 924E. I didn't stand a chance; there was no case law in the law books to support my defence of this new law.

I was given two five-year sentences for perjury because, when I bought the two shotguns, there was a box that asked if

# NEWSCIENCE NEWSCIENCE NEWSCIENCE

day), I was released from federal prison with five years' parole.

Stop! Something's wrong here... I only did 10 years of a 30-year sentence, with no chance of parole.

Well, it took the federal courts to rule that it was legal for me to possess the two shotguns; that they had no jurisdiction and they would not rule on it. The case is now pending in the First District Court.

As at September 2001, it's been four years since I've been out of federal prison and I have been a good boy, nice and quiet...until now.

## Making the Technology Available

In the past 20 years I've found out that the oil companies will do everything in their power to suppress this kind of technology because it could reduce the gasoline consumption in the United States by 76 per cent over a five-year term.

The government will lose megabucks in gasoline taxes.

The major car manufacturers will lose billions spent on the technology of the fuel injection systems. My technology makes theirs obsolete.

I've put all my patents and shop drawings up on our website for anybody to use for free! I am 58½ years young now, and the sand is running out of my hourglass fast. I don't want to take this technology to my grave with me.

If you think that I should get something out of this, then build my fuel implosion system and, after your fifth tank of gas, send me the price of a tank of gas—otherwise, I don't want a cent. If you believe that I and my patent and technology have been suppressed, then go back to the home page and vote "Yes" for this technology. Tell as many people as you can about my story. Ask them to do the same.

The reason I ask this is that I believe that millions of people around the globe want this kind of technology and know it exists. When we get enough people wanting this technology, I have powerful attorneys who know about it and are able to present it to the courts of the globe.

I will take my remaining seven cars, which have my fuel implosion system installed in them, out of exile and drive them from Boston to California with the whole world watching—and I think my chances of reaching California alive are excellent.

For more information, go to our website, [www.get113to138mpg.com](http://www.get113to138mpg.com). To make this

technology available to the public globally, vote "Yes" on the website. Or if you are one of those who oppose this type of technology, vote "No".

Thank you for your interest. Please help me spread the word far and wide.

Sincerely,  
Allen Caggiano

## Editor's Note:

Full details of Allen Caggiano's Fuel Implosion Vaporization System (US Patent #5,782,225, filed November 21, 1997, awarded July 21, 1998) are

freely available at the author's website, [www.get113to138mpg.com](http://www.get113to138mpg.com).

For general information on supercarbs/high-mileage fuel systems, visit inventor Bruce McBurne's website, [www.himacresearch.com](http://www.himacresearch.com).

This article comes via *Electrifying Times*, whose 2002 preview edition included a feature on high-mileage carburetors and their suppression by the oil and auto companies. Visit their website at [www.electrifyingtimes.com](http://www.electrifyingtimes.com) for details of more revolutionary technologies.



## United States Patent [19] Caggiano

[11] Patent Number: 5,782,225  
[45] Date of Patent: Jul. 21, 1998

[54] VAPORIZATION SYSTEM  
[76] Inventor: Allen Caggiano, P.O. Box 1273, Plymouth, Mass. 02362  
[21] Appl. No.: 975,880  
[22] Filed: Nov. 21, 1997

4,979,483	12/1996	Ray	123/557
5,000,253	3/1991	Kunzawski	165/54
5,043,518	8/1991	Hamm	123/557
5,101,801	4/1992	Schaefer	123/556
5,140,966	8/1992	Weng	123/543
5,154,154	10/1992	Henke et al.	123/549
5,218,944	6/1993	Leonard	123/557
5,291,870	3/1994	Covey, Jr.	123/545
5,337,706	8/1994	De Blasis	123/523

### Related U.S. Application Data

[63] Continuation of Ser. No. 420,749, Apr. 12, 1995.  
[51] Int. Cl.<sup>6</sup> F02G 5/00; F02M 23/14  
[52] U.S. Cl. 123/545; 165/164; 261/44.2; 261/144; 261/152  
[58] Field of Search 165/164; 123/545; 261/144, 145, 44.2, 42, 43, 152, 153, 155, 156

### FOREIGN PATENT DOCUMENTS

2404630	2/1973	Germany
3320167	12/1984	Germany
59-158986	9/1984	Japan
468076	4/1975	U.S.S.R.

Primary Examiner—Noah P. Kamen  
Attorney, Agent, or Firm—Saidel Gonda Lavorgna & Monaco, PC

### [50] References Cited

#### U.S. PATENT DOCUMENTS

1,178,900	4/1916	Smith	261/442
1,580,496	11/1934	Musselwhite	261/144
1,997,497	4/1935	Pogue	261/144
3,762,385	10/1973	Hollnagel	123/122, A
4,106,457	8/1978	Totten et al.	261/145
4,108,953	8/1978	Rocco	261/142
4,151,820	5/1979	Fursey	123/127
4,286,564	9/1981	Vin Tuyl	123/545
4,336,783	6/1982	Henson	123/557
4,377,201	3/1983	Kruse et al.	165/776
4,469,077	9/1984	Woodbridge	123/548
4,574,764	3/1986	Earle	123/545
4,579,163	4/1986	Macandl	165/54
4,603,672	3/1986	Keller	123/554
4,637,365	1/1987	Yunack	123/545
4,700,774	10/1987	Schwarz	165/140
4,862,859	9/1989	Yunack	123/545
4,883,616	11/1989	Covey, Jr.	261/64.4

### [57] ABSTRACT

A fluid vaporization system comprises a first fluid inlet for receiving a first fluid, a second fluid inlet for receiving a second fluid, and a first discharge aperture for discharging the first fluid and the second fluid. A first connecting passage connects the first fluid inlet and the second fluid inlet in fluid communication with the first discharge aperture, mixes the first fluid and the second fluid to define a fluid mixture, and delivers the fluid mixture to the first discharge aperture. A third fluid inlet receives a third fluid and a second discharge aperture discharges the third fluid. A second connecting passage in heat transfer relationship with the first connecting passage connects the third fluid inlet in fluid communication with the second discharge aperture and delivers the third fluid from the third fluid inlet to the second discharge aperture to effect heat transfer from the third fluid to the fluid mixture such that the fluid mixture is discharged by the first discharge aperture in a vaporized state.

15 Claims, 8 Drawing Sheets

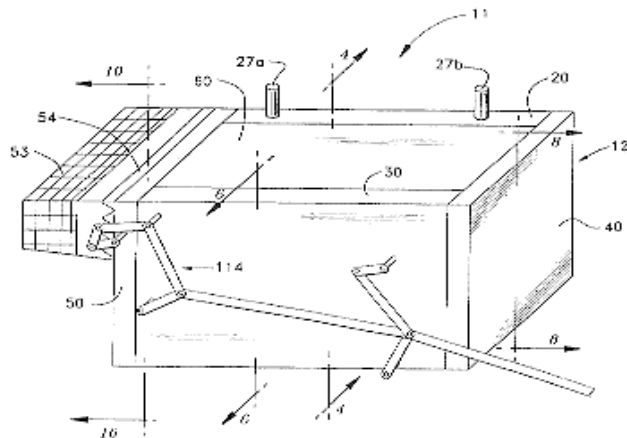



# VOLCANIC ACTIVITY, NUCLEAR TESTS AND THE UNIFIED FIELD

*The timing and location of volcanic eruptions and nuclear detonations are related to a system of geometric harmonics that conforms with equations describing the creation of the Universe.*

by Captain Bruce L. Cathie  
(Retired) © 2001

158 Shaw Road  
Oratia, Auckland, New Zealand  
Telephone: +64 (0)9 818 4291  
Email: bruce@cathie.co.nz

## A NEW THEORY OF VULCANISM BASED ON GRID HARMONICS

In my earlier works I demonstrated that all volcanic activity appears to be related to a system of geometric harmonics, based on the unified equations I discovered in my research. In my first book, *Harmonic 33*, I stated that scientists are still not certain just what does happen far below the surface of the Earth's crust to cause the conditions necessary for volcanic activity. Many theories have been put forward, but none completely explains all the facts about these mammoth disturbances.

A volcano is like a boil on the skin of the Earth. Every now and again, the pressure builds up deep inside this gigantic sore spot and it blows its top, spewing out rocks and lava to relieve the strain. Quite often thunderstorms, lightning and other weird electrical effects accompany the eruption, bringing torrential rain.

It has been noted by Japanese scientists that the magnetic field of the Earth is definitely altered in intensity and direction at the locality of a volcano just before and during an eruption. The question is: does volcanic activity produce the magnetic and electrical effects, or do the magnetic and electrical disturbances cause the volcanic activity? Now that I have checked many of these spots, I am inclined to think that the latter is the true explanation for the cause of the disturbance.

G. Gorshkov, a Russian scientist, discovered that in the case of Klyuchevskoy, possibly the highest volcano in Eurasia, there is a lenticular pocket of liquid, 25 to 35 kilometres long and 10,000 to 20,000 cubic kilometres in volume, between 60 and 70 kilometres below the surface. This was the first volcano in the world to be scientifically investigated to calculate the depth of its reservoir of molten rock.

According to Haroun Tazieff in his book, *When the Earth Trembles*, geologists speculating on more or less arbitrary notions had believed that in general the volcanic foci were to be found in the Earth's crust, much nearer the surface. Gorshkov's discovery shows that the liquid magma is found as deep as the base of the Earth's superficial crust and even just under the Mohorovicic discontinuity.

Now this is a strange thing. The plasma bowl of Mt Kilauea in Hawaii was found by seismometers to be about 55 kilometres below the surface. As the Earth's crust is only in the region of 14 kilometres below sea level at this point in the Pacific, the focal point or plasma disturbance of the Hawaiian volcano is roughly 40 kilometres below the limits of the Earth's crust. As this region of the Earth is supposed to be in a fairly plastic state in comparison with the crust itself, no scientific cause can be found to explain an area of fire and brimstone at this depth.

This leaves the field wide open for a new theory on the origin of volcanic activity. With due respect to the scientists engaged in this research, I offer a new theory based on other data discovered during my own research into the harmonic geometric nature of the unified fields that create our reality.

Over the last 37 years I have carried out extensive research into the geometric structure of matter and have discovered a series of harmonic unified equations which relate to the manifestation of our reality from the all-encompassing gravitational fields.

Initially, I discovered that an energy grid network could be calculated over the complete surface of the Earth. The basic grid structure is formed by a series of great circles interlocking at various points around the Earth's surface. The nodal points of two similar grids, when joined by a series of small and great circles, form what I loosely termed "polar squares" around the north and south geographic poles.

It was when I carried out a geometric and mathematical analysis of these sections that I found a direct connection with light, gravity, mass and electromagnetic equivalents in an harmonic sense. To do this, I had to convert all our normal systems of measurement into a single set of units and also convert our time measure into one that would correlate with the grid. After much thought and a long period of trial and error, I discovered that angular measure in minute-of-arc values and a time unit based on 27 units for one revolution of the Earth were the keys to unlocking the grid secrets.

Finally, after years of work, I discovered that I could formulate a series of harmonic unified equations which indicate that the whole of physical reality is in fact manifested by a complex pattern of interlocking wave-forms. I gradually found that the harmonic values could be applied to all branches of scientific research and atomic theory.

As time went by, much interest was being shown by intelligence agencies, government personnel and scientists in the work I

was doing and many requests started coming in for information. Help in my work was eventually offered from these quarters, but the catch was that I had to remain silent about my discoveries. This I refused to do, and I still continue to carry out my research on my own.

One of the most startling facts that I discovered by application of grid mathematics is that an atomic bomb is a device which is based on the geometrics of space and time. To be successfully detonated, the bomb must be geometrically constructed, placed on, under or over a geometric position in relation to the Earth's surface, and activated at a specific time in relation to the solar system. I found that it is possible to pre-calculate the time for various bomb tests and the location where it is possible to explode a bomb.

It was after this that I really got the attention of the scientists.

### PLANETARY GRID HARMONICS

The Earth energy grid diagram indicates that the diagonal of the polar square is 5091.168825 minutes of arc (or nautical miles) and can be broken down into a series of harmonic values:

$$\begin{aligned}
 &(5091.168825/2) \\
 &= 2545.5844120 \text{ harmonic} \\
 &\text{Reciprocal of } 2545.584412 \\
 &= 0.0003928371 \text{ harmonic} \\
 &\text{Square of } 2545.584412 \\
 &= 648 \text{ harmonic}
 \end{aligned}$$

The harmonic value of 3928371 is of extreme importance as it has a direct relationship with the Earth's magnetic field. The harmonic 648 also has many interesting associations, in particular in the harmonic table for temperature.

Further mathematical analysis of the polar sections of the world energy grid system indicated that the harmonic value for mass is equal to the harmonic of the speed of light plus the square root of the harmonic of the speed of light reciprocal, or:

$$\begin{aligned}
 \text{if } &'c' = \text{the speed of light} \\
 &'m' = \text{mass} \\
 \text{then } &m = (c + 1/c)
 \end{aligned}$$

Einstein declared that physical matter is nothing more than a concentrated field of force. What we term a physical substance is in reality an intangible concentration of wave-forms. Different concentrations of structural patterns of waves unite to form the myriad chemicals and elements, which in turn react with one another to form physical substances. Different wave-forms of matter appear solid to us because we are constituted of similar wave-forms which resonate within a clearly defined range of frequencies that control the physical processes of our limited world.

Einstein believed that the 'm' value for mass in the equation could eventually be removed and a value substituted that would express the physical in the form of pure energy. In other words, by substituting for

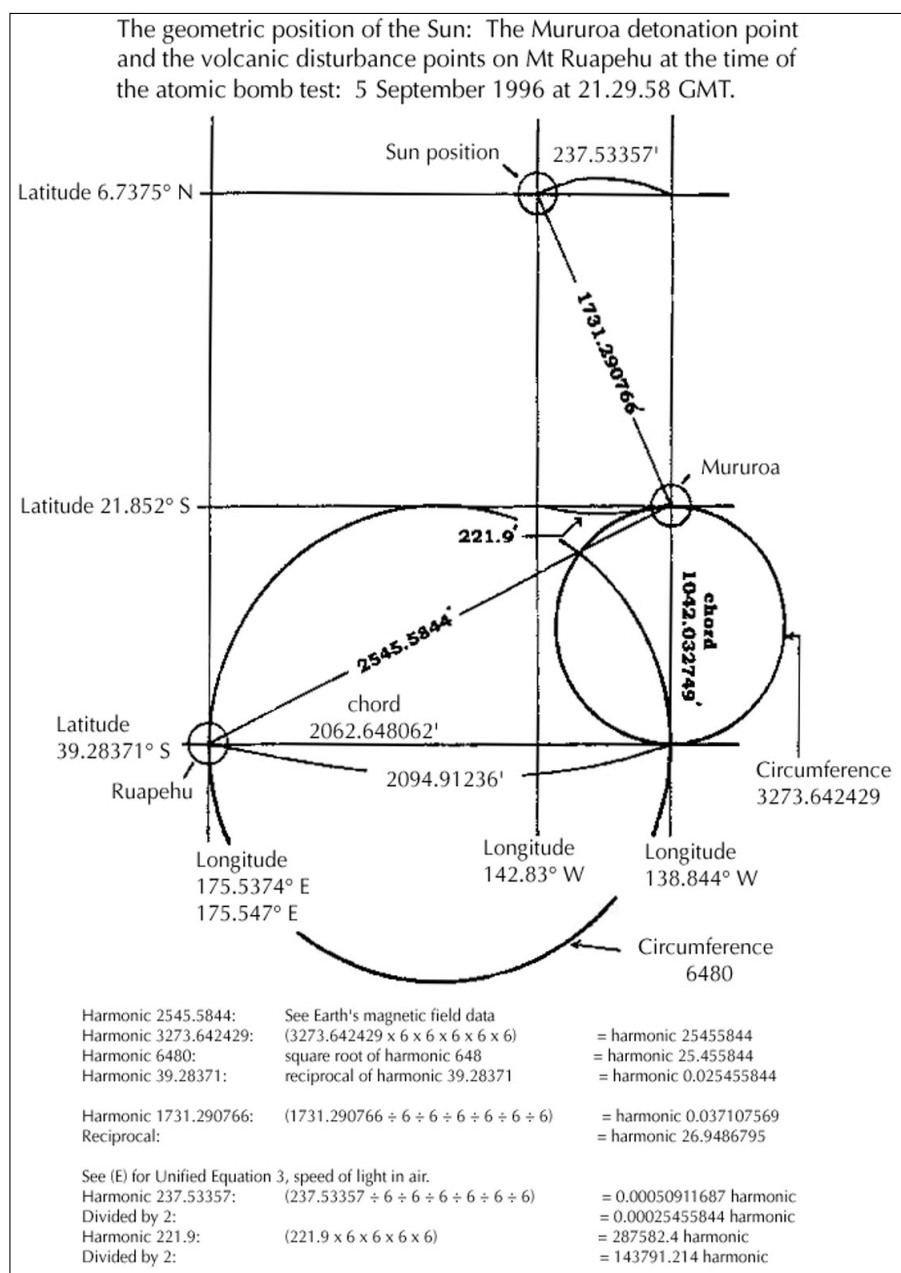

'm', a unified field equation should result which would express, in mathematical terms, the whole of existence including this Universe and everything within it. In other words, he maintained that the 'm' in his equation could be replaced by a term denoting wave-form.

I had found a substitute for 'm' in terms of the wave-form of light. So the obvious step for me was to replace Einstein's 'm' with the values of 'c' found from the energy grid system. The results are as follows:

Einstein:	$E = mc^2$	
Cathie energy grid:	$m = (c + 1/c)$	
Therefore:	$E = (c + 1/c)(c)^2$	<i>Harmonic Unified Field Equation 1</i>

I now had an harmonic unified field equation expressed in terms of light.

In the polar areas of the energy grid, the geometric values of some of the coordinates appeared to be doubled. The coordinate of 2545.584412 was doubled in the diagonals of the polar squares, and all of its associated harmonics and other factors appeared to be doubled when the pattern was projected onto a plane.

I reasoned that the way to check this idea was to increase the values of 'c' in the equation and observe the changing harmonic of 'E' to see what relative values emerged. I found what I was hunting for in the form of two more equations. One was in relation to the magnetic field of the Earth.

The Earth is simply a huge magnet, a dynamo wound with magnetic lines of force as its coils (eddy currents), counted to be 1,257 to the square centimetre in one direction and 1,850 to the square centimetre in the other direction.

The unbalanced fields of 1,257 lines of force per square centimetre in one direction and 1,850 in the other does not tell us much in itself. But if we use the information to calculate the field strength over an area that has an harmonic relationship with the unified fields of space, and if the basic information is correct, we should find some mathematical values of great importance.

It now appears that the magnetic field strengths and areas change in conjunction with the light and gravity factors according to the change in the latitude on the Earth's surface. During these changes, the harmonic relationships remain constant.

The basic unit for harmonic calculation is the geodetic inch, or one 72,000th of a minute of arc—one minute of arc being 6,000 geodetic feet (6,076 British feet). If we take the values 1,257 and 1,850 lines of magnetic force per square centimetre and make a fractional correction to allow for the curvature of the Earth's surface, we can then establish a theoretical field density of 1257.139035 lines of force in one direction and 1850.900532 lines of force in the other. This will allow the calculation of the field densities for one square geodetic inch in the north and south polar areas that can be mathematically related to the light and gravity factors.

Field A converts to: 12245.69798 lines of force per square geodetic inch.

Field B converts to: 8317.32698 lines of force per square geodetic inch.

The combined field density is equal to: 20574.234 lines of force per square geodetic inch.

The difference in field density is equal to: 3928.371 lines of force per square geodetic inch.

Or:  
 (Field A – Field B) =  $(2c + 1/2c)(2c)^2$   
*Harmonic Unified Field Equation 2*  
 = 3928.371 harmonic  
 = (144000 – 90.9345139)  
 = 143909.0655 minutes of arc  
 per grid second (harmonic)

where 'c'

**Einstein declared  
 that physical matter  
 is nothing more than  
 a concentrated  
 field of force.**

**What we term a  
 physical substance  
 is in reality  
 an intangible  
 concentration of  
 wave-forms.**

The reduction in the light speed of 90.9345139 minutes of arc per energy grid second creates a very interesting factor. The whole system of universal harmonics is based on the geometrics of the circle, the circumference of which can be divided by its radius into six equal parts. Therefore, six is the fundamental harmonic of all circular and spherical forms, and basic values can be shifted up or down this harmonic scale by multiplying or dividing by this number. Base 10 is also a part of the harmonic process and decimal points can be moved back and forth without altering the series of numbers. Zeroes before and after a number series can be ignored in harmonic calculation.

So, if we multiply the value of 90.9345139 by the six harmonic seven times:

$$90.9345139 \times 6 \times 6 \times 6 \times 6 \times 6 \times 6 \times 6 \times 6 = 2545584412 \text{ harmonic}$$

The value 2545584412, again, is the reciprocal of 3928371 harmonic.

It took many years before I was able to find the harmonic association of gravity acceleration to the unified field.

Because of a sudden hunch, I decided to check the gravity acceleration values in the textbooks and convert them into geometric equivalents in grid time. The values were in metres per second squared, and I decided to convert these progressively into British feet, geodetic feet, minutes of arc or nautical miles, and degrees based on grid time.

I started off with a value at the equator of 9.78039 metres per second squared, and when I found the value for degrees, or 60 nautical miles per grid second squared, I got a very pleasant surprise: 0.000069545205 degrees per grid second squared.

The previous speed-of-light harmonic reciprocal of 695, published in my earlier works, was within about 1/100,000,000th of the true value of gravity acceleration! No wonder the secret groups were getting uneasy about my findings.

It was becoming obvious now that gravity and the so-called "speed of light" were harmonic reciprocals of each other. As gravity increased, the "speed" of light decreased, and vice versa. Light is therefore not a "speed" in the true sense. It is an acceleration or

deceleration according to geometric position. Because of relativity, it always appears to us as a constant factor. A little bit of thought will show us that as the gravity and the light values vary, then all the physical processes will vary in direct ratio, including our measuring instruments. All the readings will appear to remain constant. Time itself will also alter in relation to the gravity and light factors.

It did not take me long to calculate a rough conversion table for the full 90 degrees from the equator to the pole. This was then extended harmonically to include the "speed of light" factors up to a maximum of 144,000 minutes of arc per grid second.

The values we read on our instruments are those calculated at zero latitude, or the equator, because of relativity. When the light factors are converted back into normal measurements of kilometres per second, etc., we see that the values match those in the textbooks.

**Harmonic Unified Field Equation 3**

$$E = [(2c + 2c)(2c)^2]$$

A series of values for 'E' can be derived from Harmonic Equation 3 when the speed of light factor is altered harmonically

between the ranges of gravity: 143791.36+ minutes of arc per grid second to 144000 minutes of arc (maximum) at the equator.

Speed of light harmonic	What/Where	Energy harmonic
143797.2143557610	gravity	2693567886
143791.3643831903	gravity	26935706
143860.9095887935	in air	2694867949
143891.3649196305	in vacuum	26954363
143909.0654800000	electromagnetic	26957666
144000	maximum	2697463486

In equations 2 and 3, the values for 'c' have been doubled to allow for antimatter which pervades our whole Universe. The scientists tell us that antimatter does exist, but say that matter and antimatter are two separate forms of reality. They also say that if matter and antimatter come into contact with each other, they will cause an explosion. If both forms exist somewhere in space, we are not told where the boundary is. Space is not empty and I believe that our Universe could not exist under these conditions. We are now told that there is more matter in the Universe than can be accounted for, and the latest term for this is "dark matter"—matter that cannot be seen.

It is obvious from my research that matter and antimatter are formed from the same wave-forms which pass through positive and negative stages. A full explanation of the theory in relation to the creation of our reality from the harmonic unified field can be found in my three books still in publication: *The Bridge to Infinity*; *The Energy Grid*; and *The Harmonic Conquest of Space*.

**KRAKATOA'S GEOMETRIC TRIGGERS**

All the mathematical evidence that I have discovered to date strongly suggests that volcanic activity is triggered by the geometric relationship of the Earth and the Sun at any given time and is directly associated with the electromagnetic and unified fields inherent in the structure of the Earth.

In fact, volcanic action appears to be manifested by the same geometric parameters that are set up for the detonation of an atomic bomb. Classic examples of the geometric process can be demonstrated in the volcanic activity at Krakatoa and Rakata Islands in the East Indies (26–27 August 1883) and at Mt Ruapehu in New Zealand (18–25 September 1995). Also, by nuclear tests at the Nevada testing grounds, USA, and at Mururoa Atoll in the South Pacific by the French.

The discovered unified equations allow for many different permutations of the geometric processes, some of which are very obscure, but the above samples give a fairly direct set of values that can quite easily be traced to the given values.

First of all, the Krakatoa eruption in 1883. On 26 August a small eruption started, causing earthquakes which gradually grew in intensity; then, on 27 August, after a series of gigantic explosions, most of Krakatoa and part of Rakata, another island in the group, were blown completely off the face of the Earth. Nearly 4.5 cubic miles of rock disappeared in this almighty convulsion, leaving a great hole deep in the sea

Diagram showing the relationship of a grid polar square to the geographic pole. Each grid has a similar pattern. The pole of each grid is set at a different latitude and longitude.

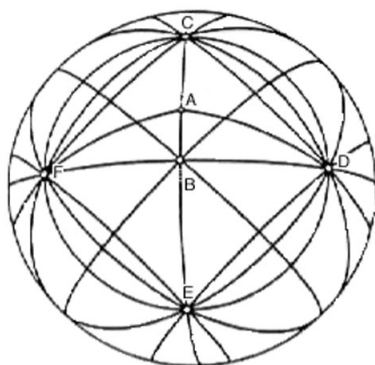

A = Geographical pole  
B = Grid pole

C }  
D }  
E } = Corner aerial positions of grid polar square  
F }

B - C }  
B - D } = 2545.584412 minutes of arc  
B - E }  
B - F }

The displacement (A - B) has a different value for each Grid.

(A - B) Grid "A" = 1054.255313 minutes of arc  
(A - B) Grid "B" = 694.8832574 minutes of arc  
(A - B) Grid "C" = 867.6871800 minutes of arc



bed and causing massive tidal waves which drowned an estimated 3,600 people. The explosions were so great that they were heard in Australia and as far away as the Indian Ocean. Even the largest atomic bomb could not duplicate the destruction caused by this great upheaval. As far as 160 miles away, the sky was darkened by the dust in the atmosphere. For months afterwards, brilliant sunsets and sunrises were seen all over the world. The fine dust drifted around the planet for years before it finally dispersed.

At the time of writing this account in my earlier publications, I was not aware that the speed of light is a variable, depending on position on the Earth's surface, and inversely related to gravity effects. Nevertheless I could see that, within the area of the massive blast, a geometric connection could be made within a certain degree of accuracy according to the unified values so far discovered in my research. A series of calculations was made and published in order to demonstrate the perceived connection.

Since that time, my research has become more advanced, and full sets of computer tables, unified values and equations are now available that allow for very accurate computer calculations to be made regarding particular points of interest on the Earth's surface.

Naturally, the Krakatoa upheaval was one of these points to be mathematically revisited. The position, within an accuracy of one minute of arc, is given in the *Times World Index* as:

Latitude: 6° 11' 00" south /  
Longitude: 105° 26' 00" east.

The latest calculations (March 1998) are as follows:

Latitude: 6° 10' 57.1193976" south  
Longitude: 105° 26' 29.616" east

The latitude is equal to 370.951989 minutes of arc.

The harmonic reciprocal of this value is 26957666.

A check of the 'E' value in the harmonic energy table will show that this is the electromagnetic energy harmonic (or 'E') calculated by Unified Equation 3 if the speed of light value is 143909.06548 minutes of arc per grid second.

$$E = [(2c + 1/2c)(2c)^2]$$

Unified Equation 3, where the speed of light is equal to 143909.06548 minutes of arc per grid second.

$$E = [(287818.131 + 1/287818.131)(287818.131)^2]$$

Using harmonics:

$$E = [(287818131 + 589441790)(82839276)]$$

$$E = (877259921 \times 82839276)$$

$$E = 726715760$$

$$E = 26957666 \text{ harmonic}$$

The longitude produces another important value which is linked with the Earth's magnetic field:

$$\text{Longitude: } 105^\circ 26' 29.616'' = 105.44156^\circ$$

We calculate the displacement in longitude the long way round from longitude zero:

$$(360 - 105.44156) = 254.55844^\circ \text{ harmonic}$$

This is associated with the 254.5844 harmonic (see the Earth's magnetic field). This harmonic can be derived from Harmonic Equation 2 using the speed of light value 143909.06548 minutes of arc per grid second, then taking the reciprocal value. (Note that the square root values change according to the decimal point position.)

$$\text{Field (A - B)} = [(2c + (1/2c)(2c)^2]$$

$$\text{Field (A - B)} = [(287818.131 + (1/287818.131)(287818.131)^2]$$

Using harmonics:

$$\begin{aligned} \text{Field (A - B)} &= (287818131 + \\ &186397860)(82839276) \\ &= (474215991)(82839276) \\ &= 39283710 \end{aligned}$$

$$\begin{aligned} \text{Reciprocal value} &= 1/0.00039283710 \\ &\text{harmonic} \\ &= 2545.5844 \text{ harmonic} \end{aligned}$$

We see from the above that the position of the eruption, at this point on the Earth's surface, has harmonic associations with the speed of light, the gravity reciprocal and the Earth's magnetic field. I do not have access to the tables that would indicate the Sun position at the time of the disturbance, but I would

expect, according to the geometric evidence, that the Sun-Earth relationship acted as the geometric trigger at the time.

## NUCLEAR TESTING AND VOLCANIC ERUPTIONS

We come now to modern times and see what these relationships have with nuclear tests. For this exercise, we will check the latitudes of some of the tests carried out at the Nevada testing ground in the United States. Copies of dates, GMT times and latitude and longitude positions as well as Sun positions corresponding with almost all of the atomic tests since the first detonation at Alamogordo have been forwarded to me over many years, allowing me to make very accurate computer calculations.

Amongst the dozens of tests carried out at Nevada, which were scattered just above and below latitude 37.1 degrees north, I have picked out the dates, GMT times and latitudes and longitudes of several tests. These have latitudes that are very close harmonically to the values ascertained from the volcanic upheaval at Krakatoa (plus or minus 200 feet) (see box overleaf).

Were they still hunting for the perfect match of the 26957666 harmonic? I do not have enough information to calculate just how far off the mark the bomb has to be before the detonation

**In fact, volcanic action appears to be manifested by the same geometric parameters that are set up for the detonation of an atomic bomb.**

will *not* occur, but possibly this is also one of the reasons for conducting the testing.

### Mururoa Test and the Eruption of Mt Ruapehu

The next example is what I believe to be the most convincing evidence discovered to date which links volcanic action and nuclear detonation. On 5 September 1995, a nuclear test was carried out at the French testing grounds at Mururoa Atoll in the Pacific:

Date: 5 Sept 1995  
 GMT: 21:29:58.40  
 Latitude: 21.852° south  
 Longitude: 138.844° west

Shortly after this test, a major eruption occurred at Mt Ruapehu, a large volcano in the central north island of New Zealand. The volcanic activity was so violent that I had a suspicion that the test, 13 days before, had a connection with the enormous pressure build-up beneath the mountain that initiated the series of explosions.

During the earlier part of the year, Ruapehu had been rumbling away a bit, but on 18 September an eruption from the crater lake caused a mudslide down one side of the mountain. Then, on 20 September, the activity increased and a public alert was given (level two on a scale of zero to five).

On 24 September, the alert was raised to level three, necessitating the closing of all the ski fields. The next day, 25 September, saw the activity accelerated enormously, with rock, ash and dense cloud being ejected from the crater. The ash and cloud rising to thousands of feet caused many roads and central airports to be closed. It was the largest eruption to occur since 1945. Between 26 September and 1 October, the activity decreased and the mountain resumed its nonactive state.

I entered the Mururoa test date data from my files into the computer and checked the geometric associations with the Ruapehu and Sun positions which occurred on 5 September 1995, and found an amazing set of interlocking harmonics which related to my unified field values.

The first value, which had been noted in my previous publications, is the latitude that passes through the Ruapehu crater: 39.28371° south. The harmonic which connects the two Earth magnetic fields is 3928371. The reciprocal of this value, of course, is the 2545.5844 harmonic.

The next startling fact that emerged from the computer was that the great-circle distance from Mt Ruapehu to the atomic test position on Mururoa was 5844 minutes of arc, again harmonically associated with the Earth's magnetic field.

There was no question in my mind that disruption of matter and the associated electromagnetic disturbances created at the Mururoa test position caused ripples through the unified field, which culminated in a heating-up effect at Ruapehu.

More work on the computer revealed a spherical triangle on the Earth's surface that broke down into further geometric coordinates related to the unified values. The coordinate between the Sun position and the detonation point of the bomb created an harmonic related to the 'E' value derived from Unified Equation 3 when based on the speed of light value in air.

Other harmonic relationships were found on the computer, but I believe the demonstrated values are enough to show without much doubt that the scientists are literally playing with fire when they mess about with the atomic structure of our immediate environment. How many other volcanic upheavals have been caused by atomic detonations since they started playing around with

these things like the sorcerer's apprentice? Are they aware of these disastrous side-effects which cause untold misery to thousands of people around the world, or are they blithely unaware of their actions and blindly carry on with the race for the superior weapon? Hopefully they will wake up to the fact one day and spend their time on more fruitful research.

Note that while making a check of the Ruapehu-Mururoa relationship, I decided to have a look once

**Krakatoa Latitude** = 370.95199 minutes of arc south  
 = 37095199 harmonic  
 = 26957666 reciprocal

Nevada Test	GMT	Latitude	Longitude
25 May 1952	12.00	37.0955°	116.1055°
22 March 1955	13.0833	37.0947°	116.0238°
29 March 1955	12.9166	37.0955°	116.1027°
15 May 1955	12.00	37.0947°	116.0238°
28 May 1957	11.9166	37.0947°	116.0236°
10 October 1958	14.50	37.0947°	116.0236°
03 June 1975	14.6666	37.0947°	116.0359°
02 April 1985	20.00	37.0947°	116.0323°

Reciprocal of harmonic 370955 = 26957447  
 Reciprocal of harmonic 370947 = 26958029

again at the geometric connection between Mount Egmont and Ruapehu. I had noted in my first book, *Harmonic 33*, that both these mountains were on the same latitude. Egmont is often called the Fujiyama of New Zealand and is a perfect cone shape set in thousands of acres of the best farmland in the Taranaki Province. Over the years, a few wisps of smoke have been seen coming out of a small vent near the top of the mountain and a few earth tremors have been felt, but to all intents and purposes this giant hunk of rock (8,260 feet/2,518 metres) has shown very little activity. But who knows? Some day...

Is it just an accident that these two mountains are positioned at a latitude of 39.28371° south (harmonic 3928.371)? This is the connection with the Earth's magnetic field.

I fed the positions of both mountains into the computer and calculated the great-circle distance between the two peaks using the Gridworks program, and was quite intrigued to find that the value was 69.545278 minutes of arc (great-circle distance) (see diagram overleaf). This happens to be the geometric harmonic for gravity when mathematically converted from the classical textbooks. The reciprocal of this value is the harmonic of light speed, 143791.214 minutes of arc per grid second (see the unified tables in my book, *The Harmonic Conquest of Space*).

The bearing of the great-circle track from Ruapehu to Egmont, given by the computer, is 269.5259 degrees, which is also harmonically significant.

I wonder what scientists will do with this piece of evidence that relates volcanic activity to the unified fields.

Note that, as stated earlier, the speed of light appears to be a constant because of the relativity factors. As the gravity values change, the speed of light changes inversely. The measurements of distance and time factors also undergo change due to the double matter/antimatter cycles. The unified tables demonstrate this. Therefore, the actual speed of light at a given latitude is quite different from the constant value we read on any instrument.

The following are the actual values calculated by the Gridworks computer program for Mururoa and the Sun at the time of detonation:

**Mururoa:** Actual speed of light (intermediate 3)  
 = 143803.5814507  
 minutes of arc per grid second

Subtracting from the maximum speed of light:  
 (144000 - 143803.5814507) = 196.4185493 harmonic  
 (196.4185493 x 6 x 6 x 6 x 6) = 254558.44 harmonic  
 = 2545.5844 harmonic

**Sun:** Latitude (at Mururoa atomic bomb detonation time):  
 Actual speed of light (gravity reciprocal)  
 = 143780.7390172  
 minutes of arc per grid second

Subtracting from maximum speed of light:  
 (144000 - 143780.7390172) = 219.2609828 harmonic  
 (219.2609828/36) = 6090580555 harmonic  
 = 3709519951 harmonic  
 Reciprocal = 26957666 harmonic

See value for 'E' in Unified Equation 3, where the speed of light is equivalent to 143909.06548 minutes of arc per grid second.

**VESUVIUS HARMONICS**

During the writing of these notes (3 May 1998), one of the local newspapers ran the headline: "Famous Volcano Set to Blow its Top. Experts fear sleeping Mt Vesuvius is preparing for a colossal eruption."

So, once again, the maps came out and the computer was switched to the Gridworks program in order to check the geometric position of the volcano and the actual speed of light values at its latitude. The results are as follows:

Latitude: 40.82833333° north  
 Longitude: 14.437616° east

Actual speed of light (electromagnetic spectrum) is equal to 143466.3019851 minutes of arc per grid second.

Subtracting from the maximum speed of light:  
 (144000 - 143466.3019851) = 533.6980149 harmonic

533.6980149 divided by 6 four times  
 = 0.411804023 harmonic  
 Squared = 0.169582553 harmonic  
 Squared = 0.028758242 harmonic  
 Divided by 2 = 0.143791214 harmonic

This is the maximum speed of light harmonic for the gravity reciprocal: 143791.214 minutes of arc per grid second.

The great-circle distance of Mt Vesuvius from longitude zero at the given latitude is 39283.71 seconds of arc—an harmonic of 3928.371 (see Earth's magnetic field).

The geometric position of the mountain appears to conform with the harmonic unified values and adds to the growing amount of evidence that helps to prove the overall unified field theory.

**Editor's Note:**

Former civil aviation pilot Captain Bruce L. Cathie (Retired) is the author of a number of books, including *The Bridge to Infinity*, *The Energy Grid* and *The Harmonic Conquest of Space*, which are still in print. These are available from NEXUS offices in Australia, New Zealand, UK and Europe, and in the USA from Adventures Unlimited Press, tel (815) 253 6390, email auphq@frontiernet.net, website www.adventuresunlimited.com. An electronic copy of *The Energy Grid* is available via email 1stbooks@1stbooks.com.

The Gridworks computer program is available through NEXUS offices as well as from Bruce L. Cathie, 158 Shaw Road, Oratia, Auckland, New Zealand, tel +64 (0)9 818 4291, email bruce@cathie.co.nz, and Rodney Maupin, Post Office Box 976, Rainier, WA 98576, USA, email gridman@ywave.com.

For additional background on Bruce Cathie's work, see his articles "The Energy Grid" in NEXUS 2/09, "The Pyramids of China" in 2/10, "The Harmonic Conquest of Space" in 2/22 and "The Harmonics of Coral Castle" in 8/06.

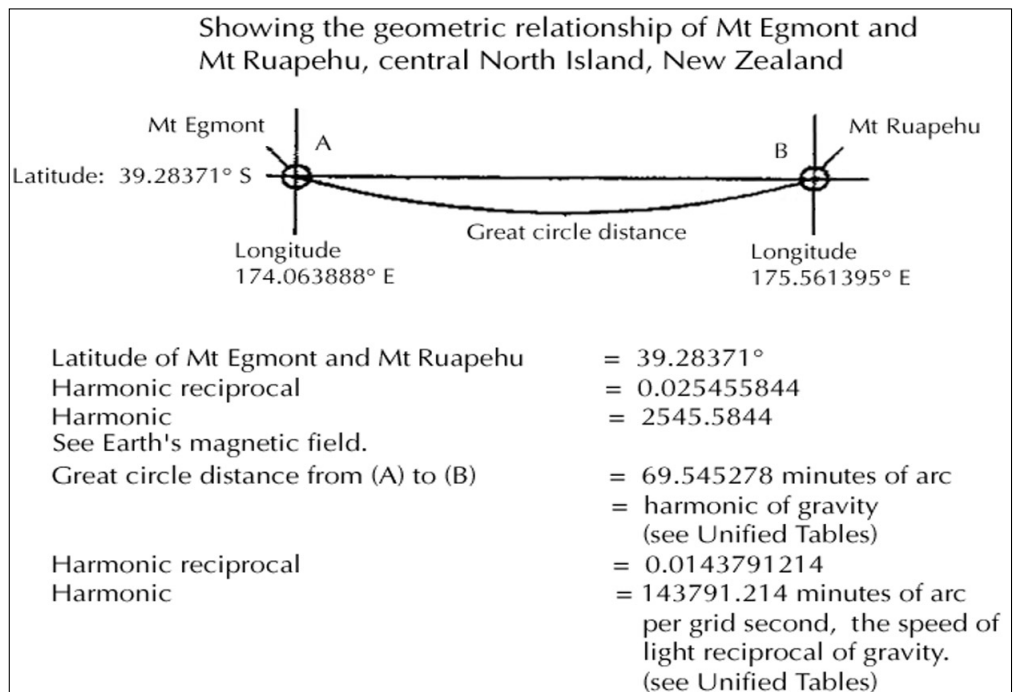



# TOWARDS FULL DISCLOSURE ON UFO/ET CONTACT

**Retired US  
Army/DIA analyst  
John Maynard  
confirms the  
existence of highly  
classified UFO files  
in military archives  
and urges the  
government to  
make a full  
disclosure on UFOs  
and alien contact.**

An interview with  
**John Maynard**  
by Theresa de Veto  
for Surfing The Apocalypse © 2001  
Website:  
[www.surfingtheapocalypse.com/  
maynard.html](http://www.surfingtheapocalypse.com/maynard.html)

**T**he following is the edited version of an exclusive interview which Surfing The Apocalypse conducted with Disclosure Project witness John Maynard, US Army Retired – Defense Intelligence Agency (DIA). It was conducted via email over a period of several weeks by Theresa de Veto for Surfing The Apocalypse ([www.surfingtheapocalypse.com/maynard.html](http://www.surfingtheapocalypse.com/maynard.html)).

Surfing The Apocalypse is denoted as SURFING. John Maynard is denoted as MAYNARD. The views expressed here are not necessarily the views of Surfing The Apocalypse, the interviewer or any of the affiliated websites.

**MAYNARD:** One might ask, with a career that includes a background in counterintelligence for both military purposes and drug trafficking, "How did you become involved in UFOs?" My involvement was probably more happenstance than anything else. I became involved while overseas in Germany, Turkey and Korea. These areas were not noted for a lot of UFO activity. I was primarily afforded the opportunity to investigate peripherally a few incidents and implement disinformation or misinformation programs to divert attention away from the military and toward the paranormal and/or UFO [followers] in those areas. However, a point I never revealed to the military was that my grandmother brought me up believing that UFOs exist.

Regardless of that point, I was still a staunch conservative (politically) and placed my military duties ahead of my beliefs. I had a "country, duty and honour" type attitude. I believed that because of my dedication and what appeared to be naivety on my part, my military superiors did not question my actions when it came to debunking UFO sightings.

However, I became very intrigued as to why UFOs were not to become public knowledge and that they (the government) preferred that any UFO information for public consumption stay in the realm of the paranormal and/or the unreliable UFO resources. It took me several years to figure out that this blatant disregard for public opinion was a plan designed to keep and maintain the pressure of proof on certain elements of our society.

The plan was basically to place the burden of proof on the UFO researchers and to steer the public away from the military organisations that were directly involved in UFO research. In this plan, I deduced that the military was using the media to keep these UFO researchers from making too much of the issue by having the media brand them as kooks, weird, paranoid and unbelievable; better yet, by having people who go around chasing after shadows in a belief that UFOs are real and the government is hiding something.

To date, this plan has worked well above average, and the general public still has an opinion that follows whatever the media tell them.

**SURFING:** Can you tell me about the pivotal point at which you decided to move out of the realm of disinformation in the UFO field and into the belief that disclosure was needed? How did you come to the decision that your beliefs should take precedence over your military duties?

**MAYNARD:** If you want to pin it down to when it started to happen, I guess it was in the early 1970s while I was in Germany. It was also the time of the famous *LA Times* publishing of "The Pentagon Papers" and Daniel Ellsberg. I was in charge of a US/NATO classified repository, and The Pentagon Papers caused me to inventory everything in the repository, right down to the last page. Part of the Ellsberg papers was classified Top Secret Cosmic, which is a NATO classification. Since I was at an Air Defense site, that particular document was in my repository, so we had to account for everything. This caused my office an untold amount of work, inventorying all the documents. It was a

page-by-page inventory. It was during that time that I realised just how much the government was hiding under its classification and disclosure blanket. Even newspaper reports that had become part of the file were being classified. It appeared to me that they literally did not want anyone to know what they knew. I guess curiosity got the best of me at that point.

After that incident, I started to pay serious attention to what was going on, particularly when it came to the classification of documents. I, more or less, became an official source to ask about classifying documents, which meant full research of the documents surrounding the one being classified.

They say that hindsight has 20/20 vision. I could have turned illegal at that point and made copies of the pages pertaining to UFO incidents. However, my security oath and duty to country stopped me from going that extra measure to the illegal.

The progression of this change in attitude and thoughts continued. While I was stationed in Turkey, I finally came to the conclusion that disclosure was needed. It took about six years to get to this point. It was also the time when I had become a Christian and was really having turmoil within myself as to which way to take a disclosure program and/or to finish my military career. I really had no means by which to

accomplish this without literally going to jail. Call it providence or whatever, but upon leaving Turkey I was assigned to DIA headquarters in the Pentagon. At that point I realised that it might be best to wait and see what else I could learn about UFOs, what the government was doing with the information and why they considered UFOs a threat to public knowledge.

That day was probably the day I made up my mind that something had to be done, and that I was being afforded the opportunity to gain information that the public does not have, and probably will never have, without disclosure. Actually, I still have difficulty with stepping out and telling what I know, but I also firmly believe that it is the time for disclosure. Full disclosure!

**SURFING:** What exactly do you mean when you say "full disclosure"?

**MAYNARD:** Exactly what it means! I feel that the government should come clean and release all the information and let the American people decide what should be done with it. Surprisingly enough, or contrary to studies done by the military and other government agencies, I believe that American citizens and the world population as a whole are ready for this kind of disclosure. It has been far too long in coming. Even at that, I doubt that the government will release everything at one time. Just a simple disclosure that UFOs exist and contact has been made with alien beings is feared by the government.

**SURFING:** Did you personally see any evidence in your work with the government that contact has been made? If so, can you tell us specifically what this "contact" entails?

**MAYNARD:** Personally, yes, as listed in the documents I was in charge of. I also knew several people who flew in and out of Nellis AFB on the Janet flights out of Las Vegas McCarran International Airport. These were government-chartered flights (unmarked) from McCarran directly to Nellis/Area 51.

**SURFING:** Can you tell us about the most convincing evidence you have encountered?

**MAYNARD:** Not any one thing was most compelling except

for, at the time, classified satellite photos and radar imagery taken during different compartmental photographic missions, such as Talent Keyhole (TK11) and by the Omni satellites. I am sure they are still classified.

As for what this information means to The Disclosure Project, it is multi-faceted. Firstly, it provides substantiation that documents do exist, as I can identify the kind and classification of them. Secondly, it provides backup documentation to other witnesses. Lastly, it establishes a basis for congressional hearings, if nothing else, to clear the problems with congressional apathy.

**SURFING:** Many theories have been put forth in regard to UFOs; they have been called everything from extraterrestrial to multidimensional, to government black-ops projects, to demonic entities. From your research and knowledge, of what do you believe the UFO phenomenon consists?

**MAYNARD:** A very loaded question, to say the least! I guess I would have to answer "D, all of the above"! Information and evidence became available to our government, mainly in the black-ops area, as you call it, which is basically covert intelligence or operations under deep cover and compartmentalisation. The information the government accumulated gave credence and

support to all of the theories: UFOs, extraterrestrials, multidimensional travel and, for those in the religious movement, what can be referred to as "demonic".

Let me put it this way: we live in a very settled but dynamic universe; it is ever-changing, yet it continues steadily in the same direction. We are not to be "the masters of this universe", nor are any of its inhabitants that are known to exist therein. However, I have a problem with this word "phenomenon", particularly as it relates to sightings and encounters that are a matter of fact.

Labelling these events as a "phenomenon" is suppression of the event by a very refined disinformation program that is in place, which is automatically mimicked, i.e., "reported", by the media. This serves in keeping the subject of UFOs in the realm of fantasy or "phenomenon" as reported.

**SURFING:** A persistent legend in regard to flying saucers is that at the end of World War II, after Germany had been defeated, a select group of Nazi military personnel and scientists escaped capture from the Allied troops and established a secret base in Antarctica, where they continued to develop advanced aircraft that may have been based on extraterrestrial technologies.

**MAYNARD:** To answer your question: I have heard the story of the German escape to Antarctica, of spaceships being built and subsequent bases on the Moon. However, I have never seen anything in writing or heard it mentioned in any conversation I had regarding documents. If there were any truth to it, it was beyond my area of classification and responsibility.

**SURFING:** From your knowledge, have you seen anything that would make you believe that any of the UFO sightings are/were craft of this nature?

**MAYNARD:** No, although I did read certain documents that indicated our own abilities in this area: back-engineered equipment, propulsion systems and alien vehicles that could provide us with the capability of travelling great distances from this planet. I have also had recent conversations in this area, but I am not prepared to go into this in detail at this time. I need to make further inquiries and confirm this information from alternate

**"Just a simple disclosure that UFOs exist and contact has been made with alien beings is feared by the government."**

sources before making a complete statement on these government activities.

**SURFING:** Do you fear that you might be reprimanded for bringing any of this evidence out now?

**MAYNARD:** No! And yes! However, I think I am at a position in life where I am comfortable in either case. Also, that my knowledge, along with the other witnesses all speaking the same language, gives me comfort. For the government to bring reprisals upon one, or all, would be more damaging in the case of rebuttal.

**SURFING:** Do you believe that the US Government has had active ongoing communications with alien species from beyond this Earth?

**MAYNARD:** Yes! There is no doubt in my mind that this is occurring.

**SURFING:** Can you tell us from where these extraterrestrials originate?

**MAYNARD:** Where do they come from? That is probably the \$64 million dollar question for everyone, except certain government offices. Personally, I do not know, as I have never read about or conversed with one of them to find out. I have heard all the rhetoric that has been spouted about Greys from Alpha Centauri or Sirius, Reptilians (which I had never heard of before seeing the term used on the Internet), and then, of course, the term of "Nordic-looking aliens". Therefore, I do not believe that I can provide any insight into this question. However, this does not mean that I lack knowledge of their existence, albeit only Greys. I have never read anything on any other species.

**SURFING:** Are you saying that in your work with the US intelligence community you have seen evidence that the "Greys" are actual extraterrestrial biological entities?

**MAYNARD:** EBEs, I do not know what else to call them—do you? They are not from this planet, but their interaction with the main populace of this planet has been very limited by government actions.

**SURFING:** How has interaction with the Greys been limited by government actions?

**MAYNARD:** "Limited" is probably too gentle of a word for what is happening. The government is trying to directly control all contact between the Greys and the populace. This is one of the reasons for the hostilities spoken of between them, and why we may hear from the Greys long before the government wants disclosure.

**SURFING:** What do you know, if anything, regarding the motivations behind the visitors to our Earth?

**MAYNARD:** I can speculate like everyone else, yet some of this information was way beyond what my clearance was allowed to read. I do know that some of that motivation has to do with our growth, not only as a species but also as a future member of an interplanetary social community that has already achieved a place in a greater universal society. How fast we get

there and what our importance will be to that community depends on many factors. At present, our government is controlling this aspect of our knowledge and until that has changed there will never be a true relationship. I firmly believe that if our government and other governments that have full knowledge of this contact do not come forward and make the announcement to the world, then the aliens will do it themselves, which most certainly will cause some panic.

**SURFING:** How long do you believe our government has had the knowledge that we are not alone in the Universe?

**MAYNARD:** That is hard to say, but I believe the United States Government—but not necessarily the elected government—had some knowledge of an alien presence as early as the mid-1800s. However, as to when official contact was made, I have never seen anything in writing on a specific date—although, through the tracking of rumours, other stated information and conversations I have had, I would estimate that official contact was made in the early to mid-1930s. Yet it could have been as early as pre-WWI (1910–14), which is long before today's popular belief of the 1950s.

Therein, because of the limited (congressional and executive branch) knowledge, the government as a whole was not prepared for the UFO crashes that occurred in the late 1940s and early 1950s. Because of this, the government stumbled dramatically, giving rise to speculation and conspiracy theories. However, with the speed of today's communications, the conspiracy advocates have a tendency to provide far more information on the event than actually occurred. Therefore, society is left with the feeling of being off balance because of who does and does not have knowledge of extraterrestrial life.

**SURFING:** You state, "I firmly believe that if our government and other governments that have full knowledge of this contact do not come forward and make the announcement to the world, then

**I believe the United States Government—but not necessarily the elected government—had some knowledge of an alien presence as early as the mid-1800s.**



the aliens will do it themselves."

**MAYNARD:** Yes, I firmly believe this, and have believed it for at least the last 20 years.

**SURFING:** If contact has been ongoing for as long as you believe that it has, why the sense of urgency from the alien standpoint to make this announcement now?

**MAYNARD:** I came to the conclusion that something was not quite right between the aliens and the people who were in contact with them. Not so much that it was stated outright, but just something that was said while I was doing background checks on cross-referenced documents. Also, in statements made during conversations with several fellow workers and my friends who worked at Area 51, it became obvious that all was not right at Groom Lake. Furthermore, other discreet conversations had indications that there was a confrontation going on between higher authority and those that had daily contact with the aliens.

However, I never learned exactly what the problems were. All I could grasp from the conversations was that there definitely was a confrontation of some kind. I have continued my research on this and believe that it is still going on today, but in a more heated sense, such as armed belligerence on both sides, with a much smaller alien presence.

**SURFING:** When you say "higher authority", do you mean persons higher up in the chain of command?

**MAYNARD:** I am referring to the chain of command. Yes!

**SURFING:** You state that "other discreet conversations had indications that there was a confrontation going on between higher authority and those that had daily contact with the aliens". Can you tell us anything about what the nature of this "daily contact" entails?

**MAYNARD:** There are certain government installations (military and/or civilian) where daily UFO and alien contact was, and is, a normal event of the day. They are: Groom Lake (Area 51) in Nevada; Dugway Proving Grounds in Utah; Cheyenne Mountain (Space Command) in Colorado; White Mountain in Arizona.

Places where it was not a normal daily activity were: California—Lawrence Livermore Laboratories, El Toro and China Lake Naval Air Stations and Edwards Air Force Base; New Mexico—Sandia Base and Los Alamos Laboratories; Florida—Eglin, MacDill and Maxwell AF Bases, which also supported the Space Centers at Canaveral and Kennedy; Maine—Loring AFB.

There were other places that had some activity which are of lesser importance and would cloud the issue.

**SURFING:** Please, tell us more about what you know about the daily events at Cheyenne Mountain.

**MAYNARD:** First off, I want you to understand a little of the background of Cheyenne Mountain which will give the reader an image of what we are talking about as it concerns daily contact.

Long before there was an organisation called Space Command,

there was the North American Air Defense Command (NORAD), set up to protect the North American continent from attack. This was the main reason for building the complex in Cheyenne Mountain. The main purpose of this joint US/Canadian organisation was to support the Strategic Air Command (SAC) and the missile Air Defense Program.

As time progressed, satellite surveillance was incorporated in the command structure of a little-known organisation called the National Reconnaissance Office (NRO). The NRO is basically a black ops-type organisation that has kept its main role in SAC as a basic cover for the new command. It was the task of the NRO to obtain information through Ariel and/or satellite imagery. As more and more space activity became involved in the process, another command was developed to handle this alone; this is called the Space Command.

It is the Space Command's responsibility to maintain an uninterrupted and consistent data flow of daily activities in Earth and near space and of space vehicles entering our atmosphere. This Command is supported by all military organisations jointly, as well as NASA and several companies from the military-industrial complex, such as Hughes, EG&G and Dryden, and SAC.

All of these organisations provide budget, manpower and support activities and it is a shared process to some degree, whereas the NRO is basically an Air Force-run operation supported by all of the military commands. All three organisations, NORAD, NRO and the Space Command, are mission-supported directly by the NSA [National Security Agency], and in turn supply processed information to the NSA.

The Space Command acts like an air traffic controller for all the activity involved in and around North America. I have been working on getting information to substantiate my allegations surrounding the daily contact.

Over the past few years there have been incidents reported or alleged that would indicate a daily UFO and/or EBE contact. Although these incidents are, at most, suspect, there seemed to be too many factors unre-

lated in each incident that struck a familiar chord. After thoroughly examining each of the incidents (which I do not feel comfortable naming at this time), and in the course of my cursory investigation of the incidents, I noted similarities and patterns of disinformation being used that would make people scoff at what was stated. After applying my knowledge of disinformation, I began to see the truth in each of the incidents. This caused me to intensify my own investigation, which is ongoing at this time and involves more than just the Cheyenne Mountain complex. I hope to have a document ready to publish with the results of what I have found, later this fall or winter.

**SURFING:** Many people have reported abduction experiences. They describe being taken against their will by aliens—usually described as the Greys—and subjected to some sort of medical examination. Some of these abductees have also

**"There are certain government installations (military and/or civilian) where daily UFO and alien contact was, and is, a normal event of the day."**



witnessed US military personnel present during the abduction experiences. What do you know about the abduction element in all of this?

**MAYNARD:** I was never exposed to any direct information on abductions. I knew that there were cases being investigated, but I never saw any reports. On a personal note, I would have to say that abductions have occurred and still are occurring today. Other than that, I do not believe I can offer anything further on this matter.

**SURFING:** Why do you think the aliens decided to interact with the government, rather than directly with the people?

**MAYNARD:** Over the years many statements have been written (fiction and/or nonfiction) concerning the best approach to this delicate subject, and I tend to agree with many of those statements. It is apparent that our species has been controlled to the large part by the government and media; whereas the *Star Trek* "Prime Directive" is probably the most famous statement, and most agree it could be the most likely scenario. However, as beings being observed for at least the last several thousand years, give or take a millennium, it will probably be less of a surprise to us in this day and age than previously thought; "Details at 11".

Yet, the factors with which we govern ourselves do not exactly bring out the best part of us. Therefore, if I were an alien studying this planet and its societies, I might be a little apprehensive about charging into the open and announcing my presence. I would probably contact one, two or more of the major governments and work with them, and, when the time was right, make a joint announcement and let history take its course. Still, regardless of what one might say, once governmental contact was made and working arrangements had been ongoing, any announcement might not be timely and might also be unproductive—that is, until

it is apparent that disclosure is necessary. In these instances, the amount of the populace's knowledge is a big factor in determining the proper time to make the announcement.

The other side of that coin might be that contact was made millennia ago, and through design it was decided that an alien presence would be counterproductive to our planetary society growth. In that case, nondisclosure might be the best scenario.

Then again, if the contact had a positive reception and disclosure had been made, interaction might be a common factor in our society and would no more be thought of than what you think of your neighbour. Some believe, as well—as I do—that we might have had an even better planetary society had acknowledgement of contact occurred positively and openly from the beginning. Primarily, you have to remember that contact is a two-way street; both parties have to be in agreement with the action to achieve the best results.

**SURFING:** That perhaps the aliens have not revealed themselves directly to us so as not to affect our natural course?

**MAYNARD:** Truthfully, I am not sure if our government—or the aliens—are the cause for the nondisclosure at this point, although personally I feel that the former is the stronger possibility. I firmly believe that if it were up to the aliens, disclosure would have been made long ago. Why else would there be so many open sightings, personal information from people all over the world and near-encounters with aliens? Also,

why would the government work so hard at denying it?

**SURFING:** Regarding these highly classified projects that you speak of involving US corporations: according to your research, were these corporations involved in "defensive" measures against the so-called "alien threat", backward engineering of captured or shared alien technologies, or all of the above and more? What can you tell us?

**MAYNARD:** The Department of Defense has had an ongoing program since the mid-1950s, which provided contracts to US civilian contractors/organisations/corporations that worked in the intelligence community. These projects came under very tight security and usually were very highly compartmentalised. What this means is that you have several concentric circles: the closer you are to the inner circle, the more information you can find on the project; the further you get away from this inner circle, the less information is available. All this is established on a very strict need-to-know basis. Within these circles you could, if you looked hard enough, find contractors that worked on various parts of the project but really had no idea what the overall project was. This also happened with the military's interaction with the primary contractor. Also in this respect, each military branch had certain projects that came under the com-

partmentalisation security measures.

What is meant by this compartmentalisation is simply the classification of a document or project, whether it is classified as Confidential, Secret or Top Secret. However, when they are named such as Umbra (UM), Majestic (MJ), Omni (OM), or Talent Keyhole (TK), the compartmented program becomes an entity unto itself. The projects and the circle of knowledge draw very tight toward the centre and access is granted or denied from within that circle. Therefore, you can literally talk with a top official in the Pentagon but, unless he has the authorisation for that particular project, he probably does not know that it exists. If he does know it exists, he knows nothing about it. Knowing the simple rules of classification helps in identifying the right person to talk with.

**SURFING:** One of the planks in The Disclosure Project platform is "To enact legislation which will ban all space-based weapons". Do you believe projects like the planned US anti-missile defence program are somehow related to the extraterrestrials?

**MAYNARD:** My political view on this is, since we cannot get along with anyone on this planet, that we justify our choice of weapons with which to defend ourselves. My ideological view is that we should ban all of our weapons, throw out our monetary systems, return to a bartering system and live in harmony with each other. Science should be shared with everyone, not just the privileged.

**SURFING:** But do you believe that some of these space-based weapons are actually being designed to do battle with extraterrestrials? If so, what effect will building them have on our "relationship" with the aliens?

**MAYNARD:** Does anyone know? We officially have not been told that our government or any other government is in contact with aliens. So how can we have a relationship? One can only speculate at this point. I firmly believe that we still have a basic fear of ourselves, thus anything alien is a basic fear for all humans. Those in power play on this point to maintain their need

**"Therefore, you can literally talk with a top official in the Pentagon but, unless he has the authorisation for that particular project, he probably does not know that it exists."**

to have weapons for self-defence, be it singular or mass destruction. As you know, we have two sides to every coin and you walk on one side at a time. Then there are those that walk on the edge between both sides. The problem comes to us as: where do you want to stand? This is something each of us has to ask ourselves at one point or another.

**SURFING:** What do you think is the reasoning behind the government secrecy and not wanting to share knowledge of an extraterrestrial interaction with Earth?

**MAYNARD:** Not a simple question to answer and we seem to be walking all around this question. I have had this question asked before and have thought about it for some time, at least for the past 35 years. Yet any answer I come up with does not really say it all.

Two of the top theories as I see it are "greed" and "secret government" theories. If you look at greed within the government (the old master and slave routine) as one possibility, it comes out with a very strong case. Then, of course, you have the secret government concept: not as strong as greed, but a very good contender in many circles. However, the all-time theory, I believe, is *power*—total and complete, unchecked power—which is a combination of greed and secrecy. This is what I believe has kept this covered up for so long and will continue to keep parts of it hidden, never to be released.

Therein, I think that The Disclosure Project has the right idea: simply disclose that UFOs and aliens exist. The rest will come later as Congress gets into the act and really finds out what the military has been up to for the past 40, 60 or more years. Even at that, there will be certain aspects that will be held very tightly and will never see the light of day as far as the average American citizen is concerned, and—in all due respect to its power—Congress also.

**SURFING:** In your opinion, what effect would full disclosure have on our social, religious and political organisations?

**MAYNARD:** Let me take each one of these aspects of our lives in reverse order.

Political life and organisations: When it comes to UFOs and alien contact, in our current system at least 98 per cent of our elected officials are as much in the dark as the rest of our citizens. It is also a simple fact that our elected officials are so greedy that they have not been able to look beyond that greed to what has been happening in our country, but I should add that this is not all-inclusive. As for world organisations, primarily within the leadership, such as the UN and industrial nations, their current level of knowledge probably goes beyond what the American populace is aware of, yet it is still shrouded in secrecy to the nth degree.

Religious organisations: For the most part, the majority will be totally and utterly devastated and receive a blow to their theology. Yet, there will be a full element within the religious community that will take this in stride and will not be shaken by the announcement. It will be that element that leads the way to a greater understanding of the scriptures and the theology of a one-God concept.

Social aspects: This is probably the most difficult to predict or

provide an assessment for. I would have to say that, as a whole, the social aspects of an alien presence will have a dramatic effect at first, which is a given fact...

#### Concluding Remarks:

**MAYNARD:** One quick note regarding weapons in space: I have two simple statements. Firstly, I believe and pray that all weapons in space will be banned. Secondly, I am also practical in understanding that where there are humans there will always be a weapon of some kind involved.

Reflecting on what has been said in this and other interviews makes me even more determined to see The Disclosure Project through, no matter what the consequences might be. We must be making some big progress because the "masters of disinformation" personalities are stepping up to their microphones and trying to make it sound like we are a bunch of crackpots.

So what do you believe? I know what I believe! I believe in what Dr Greer has started, how he has pulled the people and resources together to present a powerful message to the American people, and to ask for disclosure by our government—a message that has been denied by our government for far too many years.

In this regard, I do not believe that it any longer matters that the government has not disclosed the fact that UFOs and extraterrestrials have visited Earth on a regular basis. What matters is that the government finally stop playing its denial role and tell the truth. Yes, the truth that we have been visited repeatedly by non-Earth entities who fly in and out of our space in craft that have been sighted and photographed for many years by people just like you.

It is time that our government bring this knowledge to full disclosure, not only to the American people but also to the world as a whole, allowing other governments to follow in this brave new unfolding of our history.

I also believe that once a full disclosure has been achieved, all of the world's population will realise that we can achieve world peace, without weapons, through the technology and assistance from our galactic neighbours. It is my hope that

the people of Earth will force their governments to seek this peace—World Peace. I have heard that phrase so often that I never thought we had a hope or glimmer that it could really be possible, but it is. It is a matter of making people understand, no matter who they are, that the only solution for a more tolerant peace in our own world is to maintain peace beyond our worldly confines.

It boils down to this: Disclosure first; peace second; and no weapons in space, third! A beautiful way to really get the new millennium rolling.

#### Editor's Note:

To access testimony gathered by The Disclosure Project or to obtain a copy of *Disclosure*, *The Video* or the Briefing Document and Executive Summary on CD-ROM, visit the website [www.disclosureproject.org](http://www.disclosureproject.org). Also see Twilight Zone article and reviews in NEXUS 9/01.

**"When it comes to UFOs and alien contact, in our current system at least 98 per cent of our elected officials are as much in the dark as the rest of our citizens."**



## THE CHINTAMANI STONE AND THE CITY OF EIGHT IMMORTALS

It appears to be a trapezohedron made of black stone or ore, with glowing striations. However it is more, or less, than stone. Scientists would not be able to study it completely because it exists only partially in humanity's concept of matter and space. The Chintamani Stone is more than an artefact: it is a key to doors that were sealed aeons ago.

Part of the stone was kept in a monastery in Tibet, the second in the Museum of Natural History in New York City, and the final piece in the city of Agartha.

One ancient South American legend relates that the god Tvira built a temple on an island in Lake Titicaca to hold three holy stones called the Kala.

Similarly, three black stones were venerated by the Muslims in the Ka'aba at the Great Mosque in Mecca. There are several traditions associated with the stones, but all agree on their celestial origin. Muslims say that the stones were originally white, but turned black after absorbing dark or evil thoughts.

In Hungary, near the village of Stregocavar, there was a monolith that 19th-century occultists spoke of as being one of the keys. There was a great deal of

superstition regarding the monolith, especially the assertion that if anyone slept in its vicinity they would be haunted by monstrous nightmares of another world forever after.

In many texts, the Chintamani Stone is referred to as "the shining trapezohedron". A number of esoteric and suppressed volumes of the Gnostic tradition mentioned the original form of the stone as a trapezohedron. An Arab scholar who went by the name of Abdul Al-Hazred wrote of it in his 18th-century manuscript, the *Kitab Al-Azif*. Von Junzt alluded to it in his *Unaussprechlichen Kulten*, as did the Ponape scripture and Prinn's *De Vermis Mysteriis*.

The most recent mention of the stone is from the 1920s and directly references the reason why the stones were called "keys".

In Buddhist and Taoist beliefs, there is the tradition of "eight immortals": eight masters who reside beneath a mountain on the Chinese-Tibetan border. The city, known as Agharta in some legends and Hsi Wang Mu in others, is possibly underground and has been said by many to be near Lhasa.

There have been numerous and dubious reports of explorations of tunnels leading to the city, but the most convincing came

from Nicholas Roerich, the Russian artist and mystic (1874–1947). During his travels in Asia in the first decade of the 20th century, he heard about the eight immortals and their abode in the mountains. He learned from a native guide about a huge

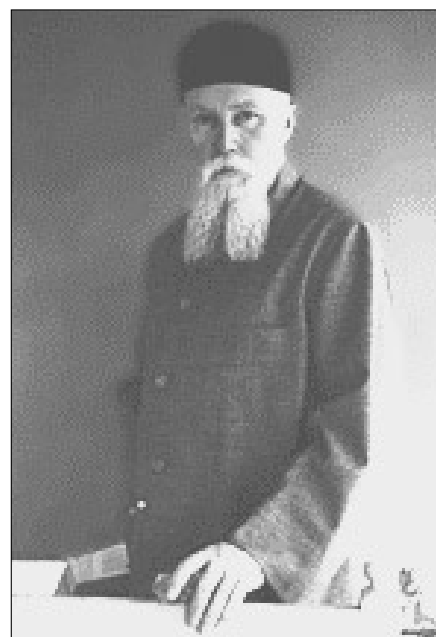

Nicholas Roerich (1874–1947)  
(Source: [www.roerich.org/NicholasRoerich.html](http://www.roerich.org/NicholasRoerich.html))

vault inside the Kunlun mountain range, where treasures had been stored from the beginning of history, and of strange, grey people.

In the 1920s, a high abbot from the Trasilumpo lamasery entrusted Roerich with a fragment of a magical stone from another world: the Chintamani Stone, alleged to have come from the Sirius system. Ancient Asian texts claim that "when the son of the Sun descended upon the Earth to teach mankind, there fell from the heavens a shield which bore the power of the world".

Roerich's wife Helena wrote that the stone possessed a dark lustre, like a dark heart, and bore four unknown letters. Roerich recognised the four letters on the stone to be Sanskrit and translated them to mean: "Through the stars I come. I bring the chalice covered with the shield. Within it I bring a treasure, the gift of Orion." Its radiation was stronger than radium, but on a different frequency.

Asian legends state that this radiation covers a vast area and influences world events, and that the main mass of the stone is kept in a tower in the city of the Starborn.

According to ancient texts, the stone was sent from Tibet to King Solomon in Jerusalem, who split the stone and made a ring out of one piece. Centuries later, Muhammad took three other fragments to

Mecca. A smaller fragment was sent with Roerich to Europe to help aid the establishment of the League of Nations. With the failure of the League, Roerich returned the fragment to the Trasilumpo lamasery in Tibet. Supposedly the 13th Dalai Lama decreed that the fragments were to be kept in separate places for safekeeping.

Roerich speculated that the stone was a form of moldavite—a magnetic mineral that is also said to be a spiritual accelerator. Some historians said that the stone could act as a homing beacon, leading to the City of the Eight Immortals.

The abbot told Roerich how the immortals were made of air and clay, formed by Mu Kung, the sovereign of the eastern air, and Wang Mu, the queen of the western air. A post-Taoist twist is that they were from a planet in the solar system of Sirius and established an outpost in the mountains of Tibet to conduct their genetic hybrid experiments.

Roerich reported that during his journey to Tibet he saw a flying disc (a term he used two decades before it was popularised). His guide had told him it was from the city of Agharta.

Roerich's theory about the stone is that it is charged with *shugs*—currents of psychic force. He speculated that it resembled an electrical accumulator and in one way or another may give back the energy stored within it. For instance, it will increase the

spiritual vitality of anyone who touches it, infusing him with knowledge or enhancing psychic abilities that allow him to glimpse Agharta, the Valley of the Eight Immortals.

The stone, according to Balam, is a key to all futures and everyone's destiny. It is a point of power, a nontechnological quantum vortex.

## References

- Agharta – Secrets of the Subterranean Cities: [www.za.spiritweb.org/Spirit/agartha.html](http://www.za.spiritweb.org/Spirit/agartha.html)
- Chintamani – Treasure of the World: [www.roerichs.org/icmr/Collection/Paintings/Chintamani.html](http://www.roerichs.org/icmr/Collection/Paintings/Chintamani.html)
- Nicholas Roerich: [www.roerich.org/](http://www.roerich.org/)
- Searching for Shambhala: [www.atlantisrising.com/shambhala.html](http://www.atlantisrising.com/shambhala.html)
- Underground Cities: [www.crystalinks.com/underciv.html](http://www.crystalinks.com/underciv.html)

(Source: [www.jamesaxler.com/dlws/g/chintamani\\_stone.htm](http://www.jamesaxler.com/dlws/g/chintamani_stone.htm))

## ROERICH'S SEARCH FOR THE SECRETS OF SHAMBHALA

Much energy has been spent by adherents to the Hollow Earth theory in trying to locate the polar entrances, specifically the northern one, to the hollow portion of the Earth. Their research material has come from many sources—for example, modern scientific methods of gathering information have been employed, from satellite pictures to seismological surveys. But earlier on, Hollow Earthers looked towards legend and folklore as well as the results of polar exploration as their sources of information.

The Bhagavat Purana, for example, contains the story of the sons of Maharaj Sagara, who were ordered by their father to search the entire globe for the sacrificial horse which had been stolen by Indra. At one point, it tells us that the sons of Sagara went off in the northeastern direction from India and entered into the interior of the Earth, where they found the horse at the hermitage of Kapila Rishi (they were not nice about it to the rishi). Other Puranas offer a bit more detail. They tell that the Sagaras came upon a northern ocean, which they passed over, and that they then entered into the bowels of the Earth.

There are traditional Tibetan Buddhist beliefs regarding the city of Shambhala and the kingdom of Agharta, in which the city is situated. Specifically, some conversations



"Chintamani – Treasure of the World" by Nicholas Roerich  
(Source: [www.roerichs.org/icmr/Collection/Paintings/Chintamani.html](http://www.roerichs.org/icmr/Collection/Paintings/Chintamani.html))

held by Nicholas Roerich, a patron of culture, with various lamas and Tibetans as he travelled in that region with his wife in the 1920s have been recorded in various books—beginning with those by Roerich himself, including *Altai-Himalaya* (1929) [see review this issue] and *Shambhala* (1930). (His artwork is still displayed at the Nicholas Roerich Museum at 319 West 107th Street in New York City.)

Roerich wrote: "I remembered how, during our crossing of the Karakorum Pass, my saïs, the Ladaki, asked me: 'Do you know why there is such a peculiar upland up here? Do you know that in the subterranean caves here, many treasures are hidden, and that in them lives a wonderful tribe which abhors the sins of the Earth?' And again when we approached Khotan the hooves of our horses sounded hollow, as though we rode above caves or hollows. Our caravan people called our attention to this... When we saw entrances of caves, our caravaneers told us: 'Long ago, people lived there; now they have gone inside; they have found a subterranean passage to that subterranean kingdom.'"

Here are some most important passages of a conversation which Roerich had with a Tibetan lama in 1928.

**Roerich:** Lama, tell me of Shambhala.

**Lama:** But you Westerners know nothing about Shambhala—you wish to know nothing. Probably you ask out of curiosity; and you pronounce this sacred word in vain.

After some cajoling by Roerich, the Lama studied him and replied:

**Lama:** Great Shambhala is far beyond the ocean. It is the mighty heavenly domain. It has nothing to do with our Earth. How and why do you people take interest in it? Only in some places, in the Far North, can you discern the resplendent rays of Shambhala... The secrets of Shambhala are well guarded.

**Roerich:** Lama, we know the greatness of Shambhala. We know the reality of this indescribable realm. But we also know about the reality of the earthly Shambhala. We know some high lamas have visited Shambhala... We know the stories of the Buryat Lama, of how he was accompanied through a very narrow secret passage... So do not tell me about the heavenly Shambhala only, but also about the one on Earth...because I know that a real one exists on Earth... Lama, how does it happen that Shambhala on Earth is still



Portrait of Nicholas Roerich in Tibetan Robes  
(Source: [www.roerich.org/online\\_collection/n/Nicholas\\_Roerich.html](http://www.roerich.org/online_collection/n/Nicholas_Roerich.html))

undiscovered by travellers? On maps you may see so many routes of expeditions. It appears that all heights are already marked and all valleys and rivers explored.

**Lama:** ...But, as yet these people have not found all things—so, let a man try to reach Shambhala without a call! You have heard about the poisonous streams which encircle the uplands. Perhaps you have even seen people dying from these gases when they come near them... Many people try to reach Shambhala, uncalled. Some of them have disappeared forever. Only a few of them reach the holy place, and only if their karma is ready.

More recently, Jan Lamprecht wrote about this subject matter in his book, *Hollow Planets* (1998). A Tibetan lama, who is a renowned teacher of Vajrayana

Buddhism and a Tibetan doctor, lectured in the San Jose, California, area and made a reference to Agharta. His title is His Holiness Orgyen Kusum Lingpa, so it seems that he belongs to a certain lineage and might be privy to ancient information on the matter. Lamprecht wrote:

"While lecturing in San Jose, this lama stated that Agharta could be reached from India by flying northwards for seven days. I would assume the lama's references were to the speed at which the bird might fly. If that is so, then the average bird flying northwards from India for seven days would easily reach the Arctic.

"Roerich's lama had stated that Shambhala lies in the Far North. Could this be a reference to the Arctic Ocean?"  
(Source: Edited from the web page [www.skywebsite.com/hollow/arctic/](http://www.skywebsite.com/hollow/arctic/))



# REVIEWS



## BOOKS

Reviewed by Ruth Parnell

### K2: QUEST OF THE GODS

by Ralph Ellis

Edu Books, UK, & AUP, USA, 2001  
ISBN 0-9531913-62-2 (UK)  
0-932813-99-2 (USA) (188pp tpb)  
Price: A\$33.00; NZ\$47.00 + p&h; £10.00;  
Euro20.90 inc. p&h; US\$16.00 + s&h  
Availability: **Australia/NZ/UK/Europe—**  
NEXUS offices; **USA—**AUP, tel (815) 253  
6390, [www.adventuresunlimitedpress.com](http://www.adventuresunlimitedpress.com)

**S**urely the architects of Khemit, ancient Egypt, received inspiration for the design of their pyramids from the natural pyramid-shaped landforms found in the desert west of the Nile. Maybe, but this is not Ralph Ellis's territory in his sequel to *Thoth: Architect of the Universe* (see review in 5/05).

Ellis reasons from his detailed studies of the geometry that the cross-section of the Great Pyramid is a map whose area can be understood when it is turned upside down. The King's Chamber is a representation of Africa, the Grand Gallery depicts India and Asia, and the roof of the Queen's Chamber portrays the Karakoram triangle near the Hindu Kush in the western Himalaya.

At the upper centre of this inverted triangle is K2, arguably the world's second-highest mountain. But what was so special about this region? Had Alexander the Great been onto something when he staged "Dionysian" expeditions there? Had the Great Pyramid, originally encased in gleaming white limestone, been built to mimic K2—a four-sided peak oriented to the four cardinal points, though having an orientation differing by 90 degrees? Was the Pyramid's causeway

designed to imitate K2's glacier? Spurious ideas, you may think, but ones that require us to think outside the square.

So what was the purpose of this signpost of antiquity? Ellis goes out on a limb, suggesting that the map points to the location of the legendary Hall of Records. And he went so far as to venture there in the hope of finding clues to hidden doorways and shafts matching those of the Great Pyramid. His expedition was foiled, unfortunately, so the ultimate test of his theory is yet to come.

### THE ORION PROPHECY

by Patrick Geryl & Gino Ratinckx

Adventures Unlimited Press, USA, 2001  
ISBN 0-932813-91-7 (264pp tpb)  
Price: A\$35.00; NZ\$49.00 + p&h; £16.50  
inc. p&h; Euro21.90; US\$16.95 + s&h  
Availability: **Aust/NZ/UK/Europe—**  
NEXUS offices; **USA—**AUP, tel (815) 253  
6390, [www.adventuresunlimitedpress.com](http://www.adventuresunlimitedpress.com)

**A** super-catastrophe will befall the Earth in late December 2012, just as it did nearly 12,000 years ago, and 12,000 years before that, says researcher Patrick Geryl. In developing his thesis for *The Orion Prophecy*, he teamed up with archaeo-astronomer Gino Ratinckx to shed light on his study into ancient Egyptian artefacts—particularly the Zodiac in the Temple of Dendera and the *Egyptian Book of the Dead* as well as the Dresden Codex of the Maya. He has discovered that these artefacts all include precise mathematical and astronomical information about the cyclical nature of these prophesied "end times" events, including knowledge of sunspot megacycles and the precession of the zodiac constellations.

The imminent sign will be in the sky when Venus moves in a retrograde circular motion

above Orion; at that time, according to the coded warnings, the Sun will erupt with megabursts of magnetic activity, which will in turn cause the Earth's magnetic field to reverse and the planet to spin in reverse and flip on its axis. The last time this happened was in 9792 BC, Geryl has deduced from the records. The resultant crustal slip, volcanic eruptions, earthquakes and mega tidal waves will lay waste to the planet and most of its inhabitants. All electronic communication systems will become inoperable.

Geryl and Ratinckx are convinced that the Egyptians and Maya had a common ancestor, the Atlanteans, who left behind additional coded information within a labyrinth in Egypt, and the authors believe they know its precise location. Geryl implores us to take this information seriously and prepare for how we might survive the cataclysm and warn future generations. As we watch our Sun exhibiting strange activity, we'd do well to ponder this Earth-shattering prophecy.

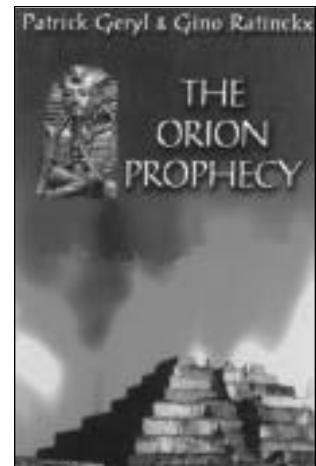



# REVIEWS

## PRINCESS DIANA: The Hidden Evidence

by Jon King and John Beveridge

SPI Books, USA, 2002

ISBN 1-56171-922-6 (408pp hc)

Price: £18.95 + £3.00 p&h; Euro31.90;

US\$19.00 + \$3.95 s&h in USA

Availability: **UK/Europe**—NEXUS offices;

**USA**—SPI Books, tel (212) 431 5011,

email sales@spibooks.com, website

www.spibooks.com

We haven't heard the last about the tragic death of Diana, Princess of Wales, and this book from investigative journalists Jon King and John Beveridge adds a few more twists to the plot. And plot it probably was. Even HRH Prince Michael of Albany, Head of the House of Stewart and President of the European Council of Princes (who wrote the foreword for the book and gave an interview to the authors) is of the opinion that Diana's death was no accident.

The authors devote only a few chapters to the anomalies surrounding the crash and its investigation before proceeding to describe the "agencies of Masonic government" that had a motive to see the Princess put out of the way. From what their government and intelligence sources have told them, the authors conclude that MI6 and the CIA had a hand in ordering the dastardly operation.

Prince Michael's contribution to the book is interesting, considering the Spencer family's historical and bloodline links with the Stewarts. The drama that unfolds is a history of power struggles between bloodlines—both legitimate and political (i.e., manipulated by Rome)—that can be traced back to the Dark Ages Merovingian kings, the kings of Judah (Jesus, Solomon and David included) and the Egyptian pharaohs.

The authors are not the first to question the legitimacy of the House of Windsor, but they do so openly in the context of its corporate power base as The Firm and how the Princess of Wales might have threatened it. The authors argue that her stand against landmines and her visit to Angola—already well supplied with landmines made in the UK—represented almost as great a threat to the British Crown and the Establishment as her relationship with Dodi Al-Fayed.

If only all this were common knowledge...

## ALTAI-HIMALAYA: A Travel Diary by Nicholas Roerich

Adventures Unlimited Press, USA, 2001

(first published 1929)

ISBN 0-932813-93-3 (423pp tpb)

Price: A\$37.00; NZ\$53.00 + p&h; £18.50

inc. p&h; Euro24.90; US\$18.95 + s&h

Availability: **Aust/NZ/UK/Europe**—

NEXUS offices; **USA**—AUP, tel (815) 253 6390, www.adventuresunlimitedpress.com

Russian-born mystic, artist, philosopher, scientist, educator, author and explorer Nicholas Roerich (1874–1947) was a true New Renaissance man. To him, beauty was the fundamental truth, and he devoted his life to expressing and appreciating this primary aesthetic. In 1920 he travelled to the USA with an exhibition of his paintings and stayed on to continue his work of uniting the arts and establishing cultural and arts centres as he had done in his homeland.

In late 1923, Roerich set out on what would become a five-year journey through some of the most beautiful and unforgiving landscapes in the world. The expedition travelled from Ceylon to India and then Kashmir; over the Himalaya and across Sinkiang; up to the Altai Mountains and on

to Omsk; then to Irkutsk near Lake Baikal, down through Mongolia and the Gobi Desert to Tibet and back over the Himalaya.

Roerich's diary of the expedition, *Altai-Himalaya*, was published in 1929, and this reprint of the original includes 20 reproductions from the inspirational artworks he painted in his travels. The apt introduction is by his US contemporary, the sacred geometrician/architect Claude Bragdon.

Roerich wrote his diary on horseback and in caravans on his journey so it has a freshness and immediacy, bringing to life the diverse peoples, places and experiences. The expedition faced many hardships, and they were detained by Tibetan authorities for five months at 15,000 feet in summer tents amidst extreme cold and deprivation.

This is a mystical travelogue, and Roerich's perspectives on sacred knowledge, ancient traditions such as Shambhala and cultural change are insightful and invaluable. (Also see Twilight Zone this issue.)

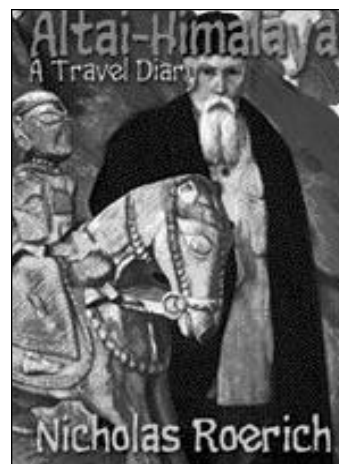



# REVIEWS



## THE HEALING MIRACLES OF COCONUT OIL

by Bruce Fife, ND

HealthWise/Piccadilly Books, USA, 2001  
ISBN 0-941599-51-5 (192pp tpb)  
Price: A\$28.00–A\$34.00; £15.00;  
Euro25.00 inc. p&h; US\$16.00 + US\$3  
s&h in USA/Canada, US\$6.00 elsewhere  
Availability: **Australia**—Empire Publishing  
Service; **UK**—Players Press, tel 01708  
749119; **Europe**—NEXUS Office; **USA**—  
Empire Publishing Service, tel (818) 784  
8918; Piccadilly Books, website [www.piccadillybooks.com](http://www.piccadillybooks.com)

For millions of people living in the tropics, the coconut is not just a staple of their diet but a preventive and curative medicine, as it has been for millennia. As a rule this traditional diet, supplemented with fruit, carbohydrate-rich vegetables and fish, means that cancer, heart disease, arthritis, degenerative disease, diabetes, etc. are virtually nonexistent in these communities.

As naturopath Bruce Fife discovered, there is a wealth of literature in the scientific and medical journals attesting to the health benefits of coconuts and coconut oil. But coconut oil—containing the medium-chain fat, lauric acid, which has similar nutritional properties to human breast milk—became the target of a smear campaign in the mid-1980s. It was orchestrated by the American Soybean Association, intent on capitalising on the public fear already stirred up by the American Heart Association that saturated fat is linked to heart disease. Ironically, the soybean oil that food makers switched to is hydrogenated—and research shows that consumption of such oils clogs the arteries and causes heart disease and stroke.

Fife's aim is to turn around this public perception and wake people up to the astounding health properties of medium-chain saturated tropical oil, especially coconut. It has powerful microbe-fighting and health-restoring abilities, so much so that it is being used successfully in the treatment of HIV, AIDS and related infections such as herpes and as a weapon against chronic fatigue syndrome, obesity, heart disease, diabetes, osteoporosis, cancer, skin disorders and more.

This information (and Dr Enig's article in this issue) has certainly opened my eyes to the wonders of this natural product—and may well do the same for you.

## YOU ARE BEING LIED TO

edited by Russ Kick

The Disinformation Company, USA, 2001  
ISBN 0-9664100-7-6 (399pp l/f tpb)  
Price: US\$19.95 + \$6.30 s&h USA/  
Canada, + US\$9.00 foreign; Euro25.90  
Availability: **USA**—The Disinformation  
Company, tel (212) 473 1125, fax (212)  
634 4316, [www.disinfo.com](http://www.disinfo.com); Consortium  
Book Sales, tel (651) 221 9035, website  
[www.cbsd.com](http://www.cbsd.com); **Europe**—NEXUS Office

The concept that "we are being lied to" is quite familiar to NEXUS readers, but sometimes it helps to remind ourselves just how it happens and get a sense of the broad expanse of territory such falsehoods can encompass. Russ Kick, on behalf of the New York-based Disinformation Company, has compiled an anthology of specially commissioned, previously unpublished and published material from a wide selection of contributors who wouldn't necessarily be assembled within the same pages.

Subtitled "The Disinformation Guide to Media Distortion, Historical Whitewashes

and Cultural Myths", this book uncovers many of the lies, untruths, half-truths, distortions, scams and gloss-overs perpetrated by the media, politicians, corporations, academics, organised religions, the scientific establishment and more. Contributors include investigative reporters, political dissidents, academic whistleblowers, media watchdogs, social critics, maverick scientists and rogue scholars. Among the luminaries are well known and underground "leftist/progressives", such as Greg Bishop, Howard Bloom, Noam Chomsky, Alex Constantine, Michael Cremo, Riane Eisler, Jim Marrs, Michael Parenti, Robin Ramsay, Douglas Rushkoff, Kenn Thomas, Jonathan Vankin and Gary Webb. (Many "rightist/conservatives" were invited to participate, but in the end all of them declined.)

Russ Kick, whose *Outposts* catalogue we reviewed in 3/03, also contributes to this well-produced, jam-packed volume that's a must for any thinking person's coffee table.





# REVIEWS

## CANCER: CAUSE, CURE AND COVER-UP

by Ron Gdanski

Nadex Publishing, Canada, 2000  
ISBN 0-685665-0-2 (473pp tpb)  
Price: A\$55.00; US\$24.95; C\$34.95  
Availability: **Australia**—Health Books Australia, tel (02) 9983 1299, website [www.healthbooksaustralia.com.au](http://www.healthbooksaustralia.com.au); **USA**—New Century Press, tel (619) 476 7400; **Canada**—Feel Better Books and Tapes, tel/fax (905) 945 2180, 800 656 7606

**A**lternative health products manufacturer Ron Gdanski writes that cancer begins when a cellular membrane wall is broken due to nutritional deficiencies, chemical toxins, viral growths, physical injury or parasites. Repair is a natural process, where the autonomic nervous system increases the current of electrical energy at the site to make DNA replicate. But when the new cells fail to connect with the old, replication goes out of control. If any of those new cells are infected, the microbes therein multiply within the cell cytoplasm. So, rather than being genetically based, cancer is "the continuous multiplication, mutation and rejection of membrane cells that fail to repair an injury", and primarily it has a microbial trigger.

Having spent six years immersing himself in the subject, Gdanski concludes that researchers as far back as Russell in the 1890s, Rife in the 1920s–30s and, more recently, Gaston Naessens and Hulda Clark, were/are all on the right track in identifying microbes—bacteria, viruses, fungi and parasites—as cancer-causing agents. Kill the microbes and keep them away, and the cancer goes. This way of thinking has already made an enormous difference to cancer patients who have opted for safer alterna-

tives over mainstream medicine's destructive, low-success solutions which are based on a false understanding of the disease.

In this comprehensive book, Gdanski also explains how and why effective cancer cures are possible—cures including restoring electrolyte balance, cleansing the lymphatic system, using amino acids and oxygen, eliminating parasites and ammonia toxicity. And he goes into how and why these cures are ignored/suppressed by vested interests within the medical/pharmaceutical industry.

This is essential reading for health professionals and interested laypersons alike.

## THE A.T. FACTOR: Piece for a Jigsaw Part III by Leonard G. Cramp

Adventures Unlimited Press, USA, 2001  
ISBN 0-932813-92-5 (375pp tpb)  
Price: A\$37.00; NZ\$49.00 + p&h; £16.50 inc. p&h; Euro21.90; US\$16.95 + s&h  
Availability: **Aust/NZ/UK/Europe**—NEXUS offices; **USA**—AUP, tel (815) 253 6390, [www.adventuresunlimitedpress.com](http://www.adventuresunlimitedpress.com)

**T**his third and final instalment of Leonard Cramp's *Piece for a Jigsaw* series is more autobiographical than the first two titles (see reviews in 4/03 and 6/06). Cramp is a British aerospace engineer, scientist, inventor and UFO researcher who has spent more than five decades developing his theories on the Cosmic Matrix and tinkering away in his workshops, creating VTOL craft and experimenting with antigravity devices and space propulsion drives—as can be seen here in the copious supporting documentary material, photographs and tech drawings.

In *The A.T. Factor* ("A.T." standing for "advanced time"), Cramp introduces his

remarkable life story with reference to key paranormal events that set the tone for his inquiries and endeavours from an early age. He goes on to describe how various "precognitive excursions" including dreams and synchronicities—forms of time travel in themselves—helped him in developing all manner of craft from disc-shaped hoverplanes to a "supercar". Such experiences which defy the notion of time as a linear constant are a normal part of living in the Cosmic Matrix, Cramp has concluded, and he obviously puts his ideas into practice.

He also explains the background to his interest in UFO propulsion and the Adamski craft sightings and relates the experiences he and his family had in observing UFOs near their home in Hertfordshire in 1954 and on the Isle of Wight in the 1960s.

Cramp's life story and works are an inspiration for inventors, UFO buffs, free energy researchers and free thinkers everywhere, and his books are classics in the genre.



# REVIEWS



## THE WORLD'S SIXTEEN CRUCIFIED SAVIORS: Christianity Before Christ by Kersey Graves

Adventures Unlimited Press, USA, 2001 (first published 1875)  
ISBN 0-932813-95-X (423pp tpb)  
Price: A\$38.00; NZ\$57.00 + p&h; £18.50 inc. p&h; Euro25.90; US\$19.95 + s&h  
Availability: Aust/NZ/UK/Europe—NEXUS offices; USA—AUP, tel (815) 253 6390, www.adventuresunlimitedpress.com

This is a reprint of the sixth edition of Kersey Graves's 1875 classic, subtitled "Christianity Before Christ", which must have caused quite a stir in its time and is still controversial. Graves's previous work was titled *The Biography of Satan*, which went into seven editions—and gives some idea of his popularity. In *The World's Sixteen Crucified Saviors*, Graves spits fire particularly at the Roman Catholic Church for basing its beliefs, dogmas, rituals and holidays on pagan precedents, hundreds and thousands of years older, but he also makes a vehement attack on all religions which hold that they were created by divine intervention—which covers most of them.

Acknowledging the seminal work of earlier scholars such as Sir Godfrey Higgins, Graves is at pains to point out the mostly oriental origins of Christianity. Apparently there were at least 16 avatars/saviours/messiahs before Jesus Christ came along, whose mythologies contain uncanny parallels: prophetic announcements, immaculate conception and virgin birth, a common birthday of 25 December, saviours of royal descent, anointing, crucifixion, resurrection, ascension and so on. Get the picture? Many of these details of JC's predecessors have been suppressed in the West, but the "superhero"

cast includes Krishna, Mithra, Osiris, Thoth, Hesus of the Druids, Prometheus, Buddha, Quetzalcoatl and more. Furthermore, the Gospel stories have older sources in ancient records such as the Vedas of India.

With a new foreword-cum-critique by scholar Acharya S, author of *The Christ Conspiracy*, this reprint is important reading for seekers of religious and spiritual truth.

## THE ATLANTIS SECRET: A Complete Decoding of Plato's Lost Continent by Alan F. Alford

Eridu Books, UK, 2001  
ISBN 0-9527994-1-3 (451pp tpb)  
Price: £18.00 (Euro orders add 10% p&h, rest of world, add 20% p&h); Euro28.80; US\$27.00 + p&h  
Availability: UK—Eridu Books, tel 01543 452577, fax 01543 370453, website www.eridu.co.uk; Europe—NEXUS office, tel +31 (0)321 380558

Independent researcher Alan Alford stated his case for the ancient Egyptian and Mesopotamian religions being "exploded planet cults" in *The Phoenix Solution* (5/06) and *When the Gods Came Down* (7/05). Now, in *The Atlantis Secret*, he presents a solid argument for Plato's Atlantis story as well as the ancient Greek religions, gods, myths and mystery schools also being based on this exploded planet idea, which was borrowed from Sumer and Egypt and has gained scientific credibility in recent years.

The original source for the Atlantis myth can be found in Plato's *Timaeus* and *Critias*, so Alford took on the Herculean task of reinterpreting Plato (a philosopher/mystic, not a geographer) in terms of the Greek world view of his time. This was a world that

believed that the stories of the gods were the literal truth, as was Plato's story of the war between Athens and Atlantis. And Plato, being an initiate into the mysteries, would have wanted to preserve knowledge of the exploded planet by encoding it in his work for those with eyes to see.

Alford concludes that the lost continent and city of Atlantis never existed here, but were located in the "heavenly" realm before they exploded, raining down on Earth and seeding the birth of the ancient Athenians. He claims that with this hypothesis he can tie up all the loose ends of Plato's account, which he acknowledges can be understood as an allegory on the social-political climate of Plato's day. But he goes further, suggesting that the Atlantis story is also a metaphor for the creation of the Universe and Time—an ancient, mystical Big Bang cosmogony.

Alford's hypothesis puts a completely new spin on ancient cultures and religions. His findings are especially relevant today as we contemplate the ever-changing Cosmos.

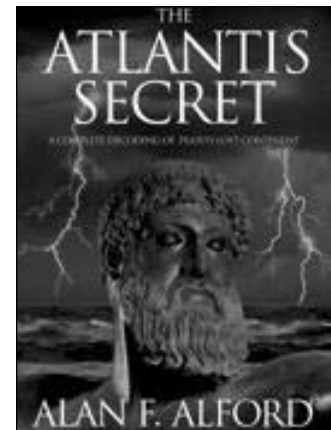



# REVIEWS

## FROM THE MOTHERLAND TO THE MOTHERSHIP

by Shurlene B. Wallace  
with Earlene V. Carr

Crystal City Publications, TX, USA, 2001  
ISBN 0-75962-871-8 (203pp tpb & hc)  
Price: US\$4.95 (e-book), US\$11.95 (tpb)  
+ US\$5.75 s&h in USA, US\$14.00 s&h to  
Canada, US\$6.75 elsewhere; Euro23.90  
Availability: **USA**—1stbooks.com, tel  
(812) 339 6000, 1888 280 7715 (toll free),  
website 1stbooks.com/bookview/6393;  
**Europe**—NEXUS Office, tel +31 (0)321  
380558, fax (0)321 318892



In 1995, Shurlene Wallace had the first in a series of life-changing paranormal experiences. They involved contact with interplanetary and interdimensional beings and travelling throughout the galaxy and dimensions in both physical and astral form. She prefers to describe them as "trips" rather than "abductions", and she reports that most of them were very positive and life-affirming. She may have been subjected to experimentation, but she also underwent some powerful physical self-healing as a result.

Uncommonly, her few contacts with so-called Greys involved their shape-shifting into other beings; on most of her travels in spacecraft and to other worlds she was accompanied by very human-looking types.

Fortunately, Shurlene had the support of her ufology-literate, identical twin sister Earlene Carr to help her make sense of her experiences psychologically and understand them in their historical and cultural contexts. After one time when Shurlene was supposedly teleported to Mars and interacted with a Black race of humans, Earlene explained (referring also to Robert Temple's *Sirius Mystery*, Credo Mutwa's depictions of aliens and the Face on Mars controversy) that various African peoples—and many fellow African-Americans—regard it as fact that they originated from the Red Planet.

Shurlene comes across as a sincere, honest

and loving person, convinced of the reality of her experiences and wanting to help others. As to how she differentiates between out-of-body astral and physical travel, the resultant symptoms are much more intense if her physical body has been disassembled for the trip! Written from the heart, her book should give reassurance to those coming to terms with their unusual experiences.

## CROP CIRCLES, GODS AND THEIR SECRETS

by Robert J. Boerman

The Ptah Foundation, Brummen, The Netherlands, 2000

ISBN 90-805716-1-X (162pp tpb)

Price: A\$25.00; NZ\$45.00 + p&h;

£10.90; Euro15.90; US\$14.00

Availability: **Australia/NZ/UK/Europe**—

NEXUS offices; **USA**—Adventures

Unlimited, tel (815) 253 6390, website

www.adventuresunlimitedpress.com

Dutch crop circle researcher Robert Boerman is a relative latecomer to the scene. He was inspired when he discovered a circular formation near his home in Brummen in 1997 and found a strange, "spiritually uplifting" crystalline residue within it. His interest in sacred mysteries set him on a path to crack the code of at least some of the glyphs that have been appearing in growing number and variety over the last 20 years in many parts of the world, particularly southern England.

In *Crop Circles, Gods and Their Secrets* (first published in the Dutch language in 1999), Boerman gives a brief history of the phenomenon, then gets down to the basics of the internal geometric construction of the circular formations. In a further move towards decoding them, he analyses the designs in terms of their being angelic seals corresponding to specific higher spiritual energies. But what do they mean?

For clues he turned to the Hebrew Gematria and alphabet, and came to realise that certain glyphs contain information about humanity's origins, our planetary history, our relationship with extraterrestrial beings who may have tampered with our DNA, and about our future. The 1991 "Dolphin" glyph, for instance, may represent the orbit of Nibiru, the "planet of the gods" known to the Sumerians and identified by Sitchin as passing through Earth's orbit every 3,600 or fewer years. Could the crop circle makers be warning us about Nibiru's imminent return, which Boerman calculates as expected in 2012? Is it the same as "Planet X", which some NASA scientists are secretly saying will wreak havoc in May 2003? Boerman's speculations are certainly thought-provoking and timely.

# REVIEWS



## TEMPEST & EXODUS

by **Ralph Ellis**

Edfu Books, UK, & AUP, USA, 2001

ISBN 0-9531913-89 (UK)

0-932813-98-4 (USA) (269pp tpb)

Price: A\$33.00; £10.00; Euro20.90;

US\$16.00 + s&h

Availability: **Aust/NZ/UK/Europe—**

**NEXUS** offices; **USA—AUP**, tel (815) 253

6390, [www.adventuresunlimitedpress.com](http://www.adventuresunlimitedpress.com)

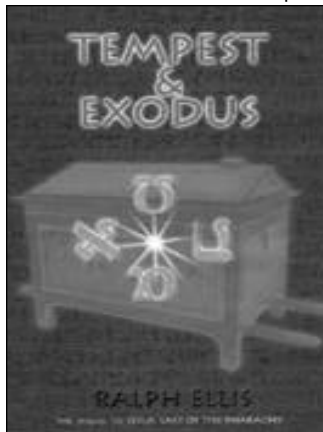

In this sequel to *Jesus, Last of the Pharaohs* (see reviews, 6/04), Ralph Ellis expands on his hypothesis about the origin of the Israelites and gives alternative translations of hieroglyphs, in the process giving quite a different perspective on the roots of Judaism and Christianity as well as the Egyptian religions. Having already established that the patriarchs of the Israelites were the Hyksos Shepherd Kings, that Abraham and Jacob were Hyksos pharaohs and that Moses was Akhenaton's brother, now Ellis provides evidence that the Hyksos originated in Lower Egypt and were not a tribe of barbaric invaders from Asia.

Fundamental to the Hyksos monotheistic religious belief system was a form of Sun/Cosmos worship centred around the Giza pyramids—structures that had to have been in place even before the rise of the first Old Kingdom dynasty, Ellis reckons from records at Heliopolis. Ultimately a clash of beliefs between Lower and Upper Egypt led to an Exodus being negotiated between the two kingdoms, ensuring that the Hyksos would leave Egypt. Their departure and the Israelites' exodus were actually one and the same event, Ellis believes.

According to the so-called Tempest Stele of Ahmose I, the Exodus plan was already on the drawing board when a great "storm" affected the land—precipitated by the eruption of Thera in the Aegean Sea c. 1625 BC—but the storm was more of a social/religious/political turmoil. Physical damage to the Upper Egyptians' architecture and icons was allegedly caused by the departing

Hyksos people, who had earlier been given all the precious materials to build a mobile temple—the Ark of the Covenant—according to the insistence of the Hyksos Pharaoh Jacob and in agreement with Ahmose I.

The notion that the Mt Sinai of the Israelites was one and the same as the Great Pyramid is just one of many surprises in this fascinating rewrite of Old Testament history.

## NEW ZEALAND'S HIDDEN PAST

by **Ross Wiseman**

Discovery Press, New Zealand, 2001

ISBN 0-473-07303-X (134pp tpb)

Price: NZ\$34.95 + p&h in NZ; overseas

orders add NZ\$10.00 p&h; US\$20.00

Availability: **New Zealand—NEXUS**

Office, tel (09) 405 1963; overseas orders:

Discovery Press, 22 Mountain Road,

Henderson Valley, Auckland 8, tel +64 9

836 0772, fax +64 9 837 6364, email

[ross\\_discovery@hotmail.com](mailto:ross_discovery@hotmail.com), website

[www.4discoverypress.com](http://www.4discoverypress.com)

Author and amateur archaeologist Ross Wiseman continues to rile the academic establishment—and members of the Maori community—with the publication of his latest book, *New Zealand's Hidden Past*. In fact, several times in 2001 he tried to launch it officially and stage an exhibition of rock marking castings, but was turned down every time. Why? Presumably because of his claim that New Zealand was settled by seafaring Phoenicians many hundreds of years before the first wave of Maori arrived.

Wiseman touched on this theory in his 1998 book, *Pre-Tasman Explorers* (see review, 5/05). He speculates that these maritime Phoenicians would have left Sidon around 677 BC, when the city was attacked by the Assyrians, and made their way via the Indian Ocean and northern Australia to settle in New Zealand in 666 BC. Here he presents many more photos and drawings of apparently Phoenician rock engravings, over 100 of them found in the Lake Taupo area in the middle of the North Island. These engravings depict all sorts of scenes including Phoenician-style ships in trouble at sea, the hunting of the now-extinct moa (a tall, flightless bird), an elephant or Hindu elephant god, as well as symbology and geometry which attests to the settlers' understanding of life, death and spirituality.

There is a map of Lake Taupo as it may have appeared prior to the huge eruption of nearby Mount Tuauhara in AD 186; and an out-of-scale though impressive map of the world including a detailed pre-186 depiction of New Zealand's North and South islands, indicating the existence of nine settlements.

This is a compelling alternative history that should be explored further, even if it treads on a few toes along the way.



# REVIEWS

## CD-ROMs

Reviewed by Duncan Roads

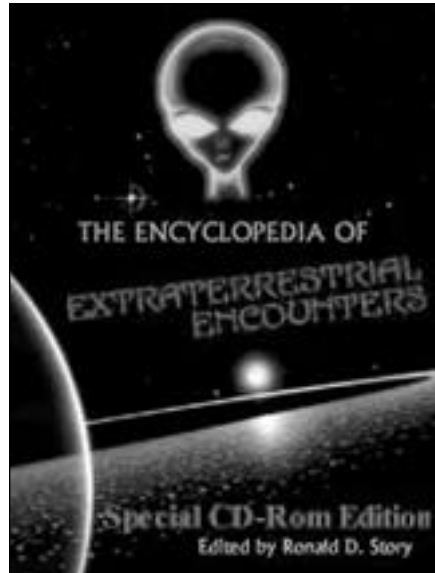

### THE ENCYCLOPEDIA OF EXTRATERRESTRIAL ENCOUNTERS Special CD-ROM Edition edited by Ronald D. Story

The UFO Encyclopedia Project, USA, 2001 (PDF & MS Word; requires Adobe Acrobat Reader)

Price: US\$9.99 inc. p&h

Distributor: **USA**—Ronald Story, 3540 32nd Avenue N. #114, St Petersburg, FL 33713, tel/fax +1 (727) 528 3789, email RonaldDStory@aol.com, website [www.RonaldStory.com](http://www.RonaldStory.com)

**K**een researchers in the field of ufology may recall a book called *The Encyclopedia of UFOs* from around 20 years ago (Doubleday/New English Library). Well, this is the updated CD-ROM version of that book.

Ronald Story is author of several UFO books from the late 1970s through early '80s, including *The Space Gods Revealed* (1976). He is an honours graduate of the University of Arizona and past member of most leading UFO organisations.

As usual, this is another CD-ROM heavily slanted towards PC/Windows platforms, but Mac "must haves" can find the PDF file of the Encyclopedia itself, and it is certainly worth the look. Also included is an MS Word file of the book. There are hundreds of well-written and up-to-date entries, photos, illustrations, articles and interactive hot links to UFO-related websites. The search-and-find capability of the PDF version of the book is terrific. A great buy!



### COSMIC ARTIST – Crop Circle Photographs, England, 1983–2001 A Unique Collection by Colin Andrews

Colin Andrews & Memorology LLC, 2001  
Minimum system requirements: MS Windows 95; 32MB RAM; Netscape Navigator 4.0, MS Internet Explorer 4.0 or America Online 4.0 web browser

(Note: Not yet available for Macintosh users, but a Mac version may be produced if there is demand)

Price: US\$29.95 + p&h

Distributors: **USA**—Available online from the website [www.CosmicArtistCD.com](http://www.CosmicArtistCD.com), or by post from Memorology LLC, PO Box 3378, Branford, CT 06405-1978 (checks payable to Memorology LLC);

**UK**—Circles Phenomenon Research, tel/fax 01264 358402

**A**t last, the CD-ROM I have been waiting for! Over 250 photographs from Colin Andrews's own camera, plus maps and captions—all interactive, with printing capability built in. The photographs cover the years from 1983 to 2001 and certainly feature the most interesting of each year's crop in the English countryside.

My only gripe with the CD-ROM is that it is not (yet) available for Macintosh computers. With PDF file technology so widely used on all platforms, I am surprised it's used so little on CD-ROMs. One day...

Having said that, though, the pictures are of very good quality. Serious researchers will appreciate the locality maps, witness statements and thumbnail pictures which accompany each photograph, plus the ability to search for specific formations via several index formats.

I was hoping to hear some of the sounds reported inside the formations and recorded by researchers over the years, but alas.

All in all, this is great value for money and a "must have" for crop circle fans and researchers alike.

# REVIEWS



## MUSIC

Reviewed by Richard Giles

### REALISE

by Karsh Kale

Six Degrees, USA, 2001 (72mins)  
Distributors: **Australia**—MRA, tel (07) 3849 6020; **UK/USA**—Six Degrees Records, [www.sixdegreesrecords.com](http://www.sixdegreesrecords.com)

**K**arsh Kale has a classical Indian tabla background and cut his musical teeth in the Asian Massive sound scene. Using electronica, he interprets the music the way an Indian musician would do, writing in various traditional styles. It makes for an album full of longer-running, snaking melodies and gorgeous Indian vocals. Singers include Vishal Vaid, Falguni Shah, Shahid Siddiqui and Ethiopian sensation Gigi. Also appearing are Indian master Ustad Sultan Khan on sarangi (Indian cello) and Steve Gorn on bansuri flute. An impressive CD, bridging electronica with traditional.

### PEOPLE'S COLONY NO. 1

by Temple of Sound &

Rizwan-Muazzam Qawwali

Real World, UK, 2001 (64mins)  
Distributors: **Aust**—MRA; **UK**—Real World, <http://realworld.on.net/colony1>;  
**USA**—Narada, [www.narada.com](http://www.narada.com)

**O**ne of the great sacred singers of the modern world, Qawwali singer Nusrat Fateh Ali Khan, came from Pakistan. He died only recently. His nephews from the UK, working under the name of Rizwan-Muazzam Qawwali, have experimented with a fusion of Western and Islamic devotional singing to produce *People's Colony No. 1*. Tracks are at breakneck speed with deep Sufi poetry and very danceable sounds. Musicians include Neil Sparkes and Count Dubulah from Trans-Global Underground, with guests Jah Wobble and Zafar Ali Khan. Exciting, glistening vocals and music.

### EUPHORIA

by Ian Cameron Smith

Rhythmist Prodns, Aust, 2001 (64mins)  
Distributors: **Australia/UK/USA**—New World Music, [www.newworldmusic.com](http://www.newworldmusic.com), [www.iancameronsmith.com.au](http://www.iancameronsmith.com.au)

**I**an Cameron Smith, the man with the amber liquid fingers, is back with his latest release, *Euphoria*, incorporating more instrumentalists to give the album international appeal and featuring vocalists including Julie Lodrick and Kirsten Anderson Skelton. Flute, saxophone and Ian's selection of guitars make this one of those fabulous relaxation albums just for sheer pleasure listening. Ian's work is among the most

heartfelt of music today, offering listeners a touch of the sublime. *Euphoria* gives peace for the mind and body in a frantic world.

### THROUGH WINDOWS & WALLS

by Peter Kater & R. Carlos Nakai

Silver Wave, USA, 2001 (47mins)  
Distributors: **Aust**—New World Music, tel (02) 9565 4522; **UK**—Discord Distribution, tel 01892 863888; **USA**—Silver Wave Records, tel (303) 443 5617, website [www.silverwave.com](http://www.silverwave.com)

**I**t's been five years since these two talented musicians last recorded together. With Kater on piano and synthesiser and Nakai on Native American flute and eagle bone whistle, this is an impressive return album. Nakai's powerful, haunting flute work and his deep vocalisations go together with the stirring piano sounds of Kater, making for a magical fusion from these two musicians who produce soul-stirring sounds as masters of their instruments. *Through Windows and Walls* deserves to make it to the top of the transformational music charts.

### AFRICAN ODYSSEY

by various artists

Putumayo, USA, 2001 (48mins)  
Distributors: **Australia**—MRA Entertainment, tel (07) 3849 6020; **UK**—Pinnacle Imports, tel 01689 870622; **USA**—Putumayo World Music, tel 1888 7888 8629, [www.putumayo.com](http://www.putumayo.com)

**M**uch African compilation music features upbeat, funky and percussion-backed styles. For this album, Putumayo brings together the acoustic and melody music of the vast African continent. Some of these artists have never before been heard outside the continent; they come from Sierra Leone, Zimbabwe, Cape Verde, Guinea-Bissau, South Africa, Kenya and Mali. These are very cool, slower, introspective sounds of Africa. Money from sales of this CD goes to African AIDS organisations.

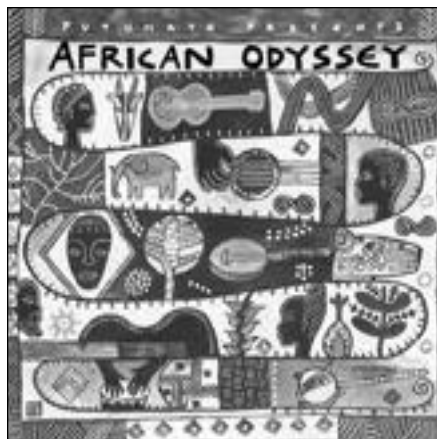

Continued from page 24

A memorandum under the letterhead of Senn, Christians & Letemeyer, and signed by Carl Herman Letemeyer (see exhibits), lists four bank accounts which collectively have a balance of US\$71 billion. The bulk of this is listed as being held in account number 4 77 22 P at Standard Chartered International Trustee Limited, London; US\$9 billion is shown under account number LVI 820975 TI at Citicorp, New York; US\$12 billion is listed under the Bank of China, Hong Kong, account number 5555 201HE; and US\$3 billion in the Bank of East Asia, Hong Kong, account number 78 9520 37 0. The memorandum is dated October 3, 1989—right in line with the Hammer and Jacobe trading programs.

This is more than interesting. Other information provided to me shows that Standard & Chartered Bank was deeply involved in the Jacobe program. According to a detailed memorandum in my possession, the trustee of the Jacobe program had "arranged that the monies be funnelled through a Trust account" of this bank.

Citibank, according to General Cocke and many others who were involved, was "the cheese" behind the Project Hammer trading program.

And then there is the Chinese connection to van Rooyen's Eastech International Bank and van Rooyen's and Stander's involvement with both Hammer and Jacobe.

### SECRET FUNDING FOR DENIABLE GOVERNMENT OPERATIONS

The foregoing has merely scraped the surface of what is an exceptionally complex and extensive story. A great deal of further investigative work is required to plumb the depths in order to present a more comprehensive account. Presently there are more questions than answers.

Hammer and Jacobe, meanwhile, are only two of many other trading programs currently under investigation by this writer. Others with names like "Redhead", "Grandmother" and "Graystone" also need investigating.

These programs eclipse more secrets than you can wag a dog's tail at. They represent the very pinnacle of covert funding for deniable government operations. Slush funds that have been generated by this

process are regularly said to be in the many trillions of dollars. This is confirmed in the deposition of General Cocke, who argues that the Hammer program "expanded" by Dan Hughes in 1989 would have become "enhanced" over the decade and now be worth over one thousand billion dollars. It is also confirmed by the documents issued by the late Baron von Krupp's Swiss lawyer, which reveal "profits" in excess of US\$12 trillion.

Amounts of this magnitude could punch a massive hole through the shortfalls in social welfare programs around the world. Famine could be eradicated from the face of the Earth, and death from easily curable diseases (in the southern hemisphere in particular), which spiral for lack of money, could easily become a thing of the past. All this could be achieved if these huge gobs of money were brought in from the cold and placed "on ledger".

But there appears to be no will to do this. Too many difficult questions and harder-to-justify explanations block the way. How would G7 governments explain to a cynical public that decades of drug money and illegal weapons sales proceeds had been laundered with their blessing (albeit in secret)



Continued from page 82

in order to win the Cold War and also to artificially prop up a political system that we call Capitalism, which would otherwise collapse under its own inherent flaws?

It took the CIA over six months to respond to a Freedom of Information Act request seeking information on Project Hammer and the Jacobe program. The request was denied under exemptions (b)(1) and (b)(3) of the FOI Act. Section (b)(1) of the Act applies to material that is "properly classified pursuant to an Executive Order in the interest of national defense or foreign policy", and exemption (b)(3) applies to the CIA Director's statutory obligation to "protect from disclosure intelligence sources and methods, as well as organization, functions, names, official titles, salaries or numbers of personnel employed by the Agency". Appeals are in progress.

For those readers who would like to view some documents relating to Project Hammer, Jacobe and the officially "non-existent" gold deposits of Severino Garcia Santa Romana, I have scanned in a half-dozen or so pages that are freely available

on my website, [www.deepblacklies.co.uk](http://www.deepblacklies.co.uk). I have also made available, at a small cost, a full copy of General Erle Cocke's 67-page deposition, together with a copy of the deposition given to German police by Rolf van Rooyen, plus a few other relevant documents which I have named the "The Project Hammer File".

Meanwhile, my investigation into Project Hammer and similar projects involving covert finance operations continues apace.

### Endnotes

4. Among the many activities that Stander and van Rooyen were engaged in—including gold dealing, setting up banks in Switzerland and Latin America, trading prime bank debentures plus numerous other "business" opportunities—they were also putting together a deal to sell a consignment of Glock pistols.

5. Janine Roberts's incredible and compelling book, *Glitter and Greed: The Diamond Investigation*, is available for purchase on the Internet via the website [www.macha.f9.co.uk/dia-suppress.html](http://www.macha.f9.co.uk/dia-suppress.html).

### About the Author:

David Guyatt has survived a 28-year career in investment banking (member, AIBD), based in the City of London. His last position was

Associate Director and Treasurer of the forfaiting (an arcane banking term meaning "to discount without recourse") division of a major international bank.

David now pursues a career in journalism, writing for a variety of media and researching and producing factual material on a wide range of associated subjects. This is his ninth article for NEXUS, the most recent ones published in 8/01 and 7/05.

In addition to his feature writing, David has prepared background papers on Anti-Personnel Electromagnetic Weapons for the International Committee of the Red Cross (ICRC), was a contributing member of ICRC's STrUS Project that sought to define criteria for judging "abhorrent weapons", and has written for the World Development Movement on his "insider's knowledge" of international weapons financing. He has been a consultant on Swiss and UK TV documentaries exposing the threat of non-lethal weapons and Britain's weapons trail to Indonesia. He is presently assisting the US-based law firm Easton & Levy in its lawsuit against the Vatican for the restitution of the Nazi Croatian Treasury which was illicitly transferred to the Vatican and elsewhere at the end of World War II.

David has recently completed an in-depth investigation into the black market of gold and has published it as an electronic book, *The Secret Gold Treaty*, available through his home page, [www.deepblacklies.co.uk](http://www.deepblacklies.co.uk).

### Endnotes

39. *The Records of Rome*, 1868, British Library, ILS 7317, "Silvani" (plural).
40. Born in 42 BC, Emperor during the years AD 14–37.
41. Suetonius, *The Life of Augustus* (trans. Philemon Holland), Tudor Series, 1893.
42. Hardy, E.G., *Res Gestae*, 1923.
43. *Shorter Oxford Dictionary*, p. 1503.
44. Marsh, F.B., *The Reign of Tiberius*, 1931.
45. Cooper, J.C. (editor), *Brewer's Myth and Legend*, Cassell, 1992, p. 213.
46. Beesly, *Catiline, Clodius and Tiberius*, 1878.
47. *Smaller Classical Dictionary*, 1910 ed., "Tiberius".
48. Suetonius, *The Twelve Caesars*, ch. 3:5, p. 112 (trans. R. Graves, 1958).
49. *ibid.*
50. *ibid.*
51. *ibid.*
52. Suetonius, *op. cit.*, ch. 3:18, p. 119.
53. *ibid.*, ch. 3:17, p. 119.
54. *ibid.*, ch. 3:9, p. 114.
55. *Smaller Classical Dictionary*, *ibid.*, "Tiberius". Also *The Records of Rome*, *ibid.*
56. *Encyclopaedia Britannica*, "Palatine".
57. *Encyclopaedia Judaica Jerusalem*, 1971, p. 601.
58. *Chronicles of Geoffrey of Monmouth*, 4,11.
59. Waddell, L.A., *The Phoenician Origin of Britons, Scots and Anglo-Saxons*, 1924, p. 390.
60. *British Chronicles*, Fowler & Rowe, c. 1854.
61. Bunson, M., *Encyclopaedia of the Roman Empire*, Facts on File, New York, 1994, "Augustus".
62. Josephus, *Jewish Wars*.
63. John 11:16, 20:24 and 21:2.
64. *Song of Solomon* 7:14.
65. *Encyclopaedia of Early Christianity*, 1990, pp. 899-900.
66. Ephraim the Syrian, *Homily on the Life of a Pilgrim*, CCPG 1, 1152-115, TLG 1214.
67. *Chronologie*, ii, 172.
68. Lingard, Prof. John S.J., "About the Acts of Thomas: A Paper", 1952, chapter 31, p. 148.
69. Thomas 138:7f, 138:19f.
70. Prologue, Gospel of Thomas. Also Introduction to the Acts of Thomas.
71. *Catholic Encyclopaedia*, vol. XIV, 1912, p. 658.
72. Layton, Bentley, *The Gnostic Scriptures*, 1987, p. 370.
73. Acts of Thomas 108:1.
74. Acts of Thomas, Syrian Version, 110:56.
75. Schaff, Philip, DD, *History of the Christian Church*, Ms. 283, Chicago Public Library.
76. Harris, Rendel, *Cult of the Heavenly Twins*, 1906.
77. Pliny the Elder (Caius Plinius Secundus), *Natural History*, book VI, Hepworth & Sons, UK, rep. 1934.
78. Tacitus, *Annals*, 11:84.
79. Pope Alexander VI, 1492–1503.
80. Pope Leo X, Giovanni de Medici, 1513–1521.
81. *Oxford Dictionary of Popes*, Oxford University Press, p. 258.
82. British Museum, Ms. 279V.
83. *Catholic Encyclopaedia*, vol. IX, 1910, p. 153. Also T.W. Doane, *Bible Myths*, Charles P. Somerby, Truth Seeker Co., reprinted 1949, p. 438.
84. The name "Rennes" (-le-Château) is of more recent origin. The Romans called it "Rhedae".
85. Baigent, Michael, Richard Leigh and Henry Lincoln, *The Holy Blood and The Holy Grail*, Corgi Books, 1982, 1990.
86. Neyman, M.G.E.H., *The True Language of Rennes-le-Château*, Belgique, Books on CD-ROM.
87. Neyman, M.G.E.H., *The Horse of God*, Belgique, Books on CD-ROM.
88. Baigent, Leigh and Lincoln, *op. cit.*
89. John 20:24.
90. Mark 6:3, Matthew 13:55.

### About the Author:

Tony Bushby, an Australian, became a highly successful businessman and entrepreneur very early in his life. He established a magazine publishing business and spent 20 years researching, writing and publishing his own magazines, primarily for the Australian and New Zealand markets.

With strong spiritual beliefs and an interest in metaphysical subjects, Tony has developed long relationships with many associations and societies throughout the world. He has been given access to rare biblical manuscripts in the archives of numerous private libraries and museums. *The Bible Fraud* involved him in 12 years of full-time, painstaking research at great personal expense. His extensive travels have taken him to Egypt, the Middle East, England, Wales, Scotland, France, Germany, Belgium, Italy, Australia, New Zealand and the USA. He is currently abroad, preparing further manuscripts to follow *The Bible Fraud*.

As Tony Bushby vigorously protects his privacy, any correspondence should be sent to him care of Joshua Books, PO Box 5149, Maroochydore BC, Qld 4558, Australia, tel +61 7 5444 1971, fax +61 7 5444 1491. Copies of *The Bible Fraud* are available from NEXUS offices, Joshua Books and via the website [www.the.biblefraud.com](http://www.the.biblefraud.com) (see review in NEXUS 8/06).

## Hidden from History: The Canadian Holocaust

Continued from page 40

*sometimes Department of Defense people. The Catholics did it big time in Quebec when they transferred kids wholesale from orphanages into mental asylums. It was for the same purpose: experimentation. There was lots of grant money in those days to be had from the military and intelligence sectors: all you had to do was provide the bodies.*

*The church officials were more than happy to comply. It wasn't just the residential school principals who were getting kickbacks from this: everyone was profiting. That's why it's gone on for so long. It implicates a hell of a lot of top people. (From the Closed Files of the IHRAAM Tribunal, containing the statements of confidential sources, June 12–14, 1998)*

Such experiments and the sheer brutality of the harm regularly inflicted on children in the schools attest to the institutional view of aboriginals as "expendable" and "diseased" beings. Scores of survivors of 10 different residential schools in BC and Ontario have described under oath the

following tortures inflicted on them and other children as young as five years old between the years 1922 and 1984:

- tightening fish twine and wire around boys' penises;
- sticking needles into their hands, cheeks, tongues, ears and penises;
- holding them over open graves and threatening to bury them alive;
- forcing them to eat maggot-filled and regurgitated food;
- telling them their parents were dead and that they were about to be killed;
- stripping them naked in front of the assembled school and verbally and sexually degrading them;
- forcing them to stand upright for more than 12 hours at a time until they collapsed;
- immersing them in ice water;
- forcing them to sleep outside in winter;
- ripping the hair from their heads;
- repeatedly smashing their heads against concrete or wooden surfaces;
- daily beating without warning, using whips, sticks, horse harnesses, studded metal straps, pool cues and iron pipes;
- extracting gold teeth from their mouths without painkillers;
- confining them in unventilated closets

without food or water for days;

- regularly applying electric shocks to their heads, genitals and limbs.

Perhaps the clearest summary of the nature and purpose of such sadism are the words of Bill Seward of Nanaimo, a survivor of the Kuper Island school:

*The church people were worshipping the devil, not us. They wanted the gold, the coal, the land we occupied. So they terrorised us into giving it to them. How does a man who was raped every day when he was seven make anything out of his life? The residential schools were set up to destroy our lives, and they succeeded. The whites were terrorists, pure and simple. (Testimony of Bill Seward to Kevin Annett and IHRAAM observers, Duncan, BC, August 13, 1998)*

### Editor's Note:

To obtain a copy of "Hidden From History: The Canadian Holocaust", contact The Truth Commission into Genocide in Canada, c/-6679 Grant Street, Burnaby, BC V5B 2K9, Canada, telephone +1 (604) 293 1972, email kevinannett@yahoo.ca or kevin\_annett@hotmail.com, or visit the website <http://annett55.freewebsites.com>. See review, NEXUS 9/01.